

Installation and maintenance instructions

Gas wall hung Boiler condensing
Buderus 500 - 24/S

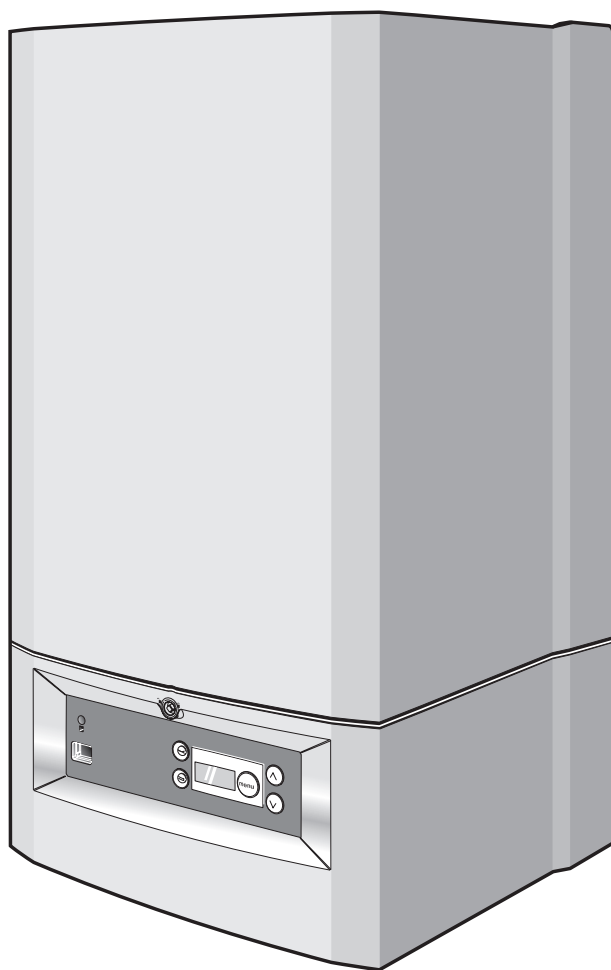

Buderus



The boiler meets the basic requirements of the appropriate standards and directives.

Conformity has been substantiated by the proper documents which - together with the declaration of conformity - are filed with the manufacturer.

Subject to technical modifications!

Constant development efforts may result in minor deviations in illustrations, functional steps and technical data.

Updating the documentation

If you have suggestions for improvement or have found discrepancies, please do not hesitate to contact us.

Contents

1	Installation	7
1.2	Dimensions, connections and assembly	9
1.3	Items supplied with unit	10
1.4	Hanging the boiler	10
1.5	Water circulation system	11
1.6	Pipe connections	11
1.7	Flue Installation	15
1.8	Electrical connections	21
1.9	DBA wiring diagram	21
1.10	Electrical wiring diagram	22
1.11	System examples	27
2	Commissioning	30
2.1	Preparing the boiler for operation	30
3	Inspection	40
3.1	General directions	40
3.2	Preparing the boiler for inspection	40
4	Maintenance	41
4.1	Cleaning the heat exchanger and burner	41
4.2	Cleaning the condensate trap and syphon	42
5	Appendix	43
5.1	Fault codes	43
5.2	Residual pump lift	44
5.3	Spare parts list	44
6	Index	47

G. C. Appliance No. :

Buderus 500-24/S 41-110-24

Other manuals available for this boiler are:

- user manual;
- service instructions;
- wall spacing frame instructions.

Preface

These Installation and maintenance instructions apply to:
Buderus wall-mounted condensing gas system
boilers 500 - 24/S.

Model: C_{13(x)}, C_{33(x)}, C_{53(x)}, C_{73(x)}

Type: GB/IE II_{2H3P} 20 mbar, 37 mbar

In this document: NG = 2H-G20-20 mbar

LPG = 3P-G31-37 mbar

Power rating: 230 VAC, 50 Hz, IP X4D

Fuse rating: 2.5 Ampere slow blow sand filled

The boiler unit consists of the following components:

- **500** Gas condensing boiler
- **24** Maximum output is 24 kW
- **S** System boiler.

Important general instructions for use

Only use the boiler in accordance with its designated use and the installation and maintenance instructions. Installation, maintenance and repair must be carried out by competent service engineers (e.g. CORGI registered). Only use the boiler in conjunction with the accessories and spare parts indicated in the installation and maintenance instructions. Other accessories and consumables may only be used if they are expressly provided for the designated use and if system performance and safety are not affected in any way.

The boiler is suitable for connection to fully pumped, sealed water systems ONLY. Adequate arrangements for completely draining the system by provision of draining valves must be provided in the installation pipework.

Pipework from the boiler is routed downwards as standard, but may be routed upwards behind the boiler using the wall spacing frame.

Subject to technical modifications.

As a result of our policy of constant development, there may be small differences between illustrations, functional steps and technical data.



BENCHMARK' Log Book

All Buderus gas fired boilers now include an installation, commissioning and service record log book.

The details of the log book will be required in the event of any warranty work being requested.

Please complete the appropriate sections on completion of the installation and commissioning.

REMEMBER: Please hand the log book back to the user.

Regulations and directives

It is a requirement that all gas appliances are installed and serviced by a CORGI registered installer in accordance with the regulations. Failure to install appliances correctly could lead to prosecution. It is in your own interest, and that of safety, to ensure the law is complied with.

The installation must also be in accordance with the latest I.E.E (**BS.7671**) Wiring Regulations, water regulations, the building regulations and the Building Standards (Scotland) and any relevant requirements of the local authority.

It is a requirement and in your own interest, and that of safety that this boiler must be installed by a CORGI registered installer, in accordance with the relevant requirements of the current Gas Safety (Installation and Use) Regulations, The Building Regulations, current I.E.E. Wiring Regulations and the relevant British Standard Codes of Practice.

Detailed recommendations are contained in the following British Standard Codes of Practice:

- BS. 5440:1** Flues (for gas appliances of rated input not exceeding 70 kW).
- BS. 5440:2** Ventilation (for gas appliances of rated input not exceeding 70 kW).
- BS. 5449** Forced circulation hot water systems.
- BS. 5546** Installation of gas hot water supplies for domestic purposes (2nd. family Gases).
- BS. 6798** Installation of gas fired hot water boilers of rated input not exceeding 60 kW.
- BS. 6891** Low pressure installation pipes.
- BS. 7593: 1992:** Code of practice for treatment of water in domestic hot water central heating systems.
- IGE/UP/1b** Tightness testing and purging domestic sized gas installations.

Health and & Safety Document No. 635.

The Electricity at Work Regulations, 1989.

The manufacturer's notes must not be taken, in any way, as overriding statutory obligations.

The design and construction of the Buderus wall-mounted condensing gas system boiler 500-24/S conforms to the basic specifications listed in the European directive governing gas-fired appliances 90/396/EEC, and with respect to EN 625, EN 483 and EN 677.



NOTE

Observe the corresponding technical rules and the building supervisory and statutory regulations when installing and operating the system.



WARNING!

Keep the burner-control unit housing CLOSED when working on water-bearing components.



NOTE

The heating boiler is designed exclusively for heating water as part of a central heating system and/or hot-water system.



NOTE

For optimum, long-term reliable functioning of the heating boiler, and in order to be able to claim under the terms of the manufacturer's warranty, the heating boiler must be inspected and maintained at least once a year (under normal operating conditions) by an officially recognized installation and service engineer. The term "normal operating conditions" means that the heating boiler is used to provide central heating and/or hot water to no more than one single-family dwelling.



NOTE

When instructions aren't followed, warranty expires.



NOTE

Condensing boilers work more efficient if the CH flow/return temperature is as low as possible.

Timber Framed Buildings

If the boiler is to be fitted in a timber framed building it should be fitted in accordance with the Institute of Gas Engineering document **IGE/UP/7:1998** and **BS 5440:1**.

Bathroom Installations

This appliance is rated IP X4D.

The boiler may be installed in any room or internal space, although particular attention is drawn to the requirements of the current IEE (**BS.7671**) Wiring Regulations and, in Scotland, the electrical provisions of the building regulations applicable in Scotland, with respect to the installation of the boiler in a room or internal space containing a bath or shower. If the appliance is to be installed in a room containing a bath or shower then, providing water jets are not going to be used for cleaning purposes (as in communal baths/showers), the appliance can be installed in Zone 3, as detailed in **BS.7671**.

Compartment Installations

A compartment used to enclose the boiler should be designed and constructed especially for this purpose.

An existing cupboard or compartment may be used, provided that it is modified for the purpose.

In both cases, details of essential features of cupboard/compartment design, including airing cupboard installation, are to conform to the following:

BS 6798 (No cupboard ventilation is required - see 'Air Supply' for details).

It is not necessary to have a purpose-provided air vent in the room or internal space in which the boiler is installed. Neither is it necessary to ventilate a cupboard or compartment in which the boiler is installed, due to the low surface temperatures of the boiler casing during operation; therefore the requirements of **BS 6798**, **Clause 12**, and **BS 5440:2** may be disregarded.

The permanent clearances required are:

in front:	8 mm
below:	21 mm
right side:	8 mm
left side:	8 mm
above:	21 mm

The position selected for installation MUST allow adequate space for servicing in front of the boiler. See table below:

in front:	350 mm
below:	180 mm
right side:	8 mm
left side:	8 mm
above:	200 mm

In addition, sufficient space may be required to allow lifting access to the wall mounting bracket.

Wall-mounted condensing gas system boilers must only be operated with Buderus purpose made gas systems, which are certified for this type of boiler.

Observe the relevant standards, regulations and legislation of the country or region of final use.



CAUTION

Use this device for its intended purpose only.



DANGER!

notes relating to the heating system water.

Thoroughly flush the system before it is filled with water. Use only untreated water or water treatment product such as Sentinel X100 to fill and top up the system. For more information about Sentinel call 0151 420 9563.

When using water treatment, only products suitable for use with Buderus heat exchangers are permitted (e.g. Sentinel X100). Your warranty is at risk if an incorrect water treatment product is used in conjunction with this appliance.

For more information, contact Buderus Technical Product Support Department.

It is most important that the correct concentration of the water treatment product is maintained in accordance with the manufacturer's instructions.

If the boiler is used in an existing system any unsuitable additives MUST be removed by thorough cleaning. **BS.7593:1992** details the steps necessary to clean a domestic central heating system.

In hard water areas, treatment to prevent lime scale may be necessary - however, the use of artificially softened water is NOT permitted.

Under no circumstances should the boiler be fired before the system has been thoroughly flushed.

Do not use artificially softened water.

Only plastic pipework containing a polymeric barrier should be used.

It is allowed to use copper for the first 600 mm. See also subsection 1.6 "Pipe connections" in this manual.



NOTE:

notes relating to domestic hot water.

- The domestic hot water service must be in accordance with **BS 5546** and **BS 6700**.
- The boilers are suitable for connection to most types of washing machine and dishwasher appliances.
- When connecting to suitable showers, ensure that:
 - a. The shower is capable of accepting mains pressures and temperatures up to 65 °C.
 - b. The shower is ideally thermostatic or pressure balancing.
- Where temporary hardness exceeds 150 mg/litre, it is recommended that a proprietary scale reducing device is fitted into the boiler cold supply with the requirements of the local water company



CAUTION

Provision must be made to accommodate the expansion of DHW contained within the appliance, where a back flow prevention device is fitted **BS. 67989: §5.4.3**.

Safe handling of substances

No asbestos, mercury or CFCs are included in any part of the boiler and its manufacture.

Hazard definitions and abbreviations

Hazard definitions



DANGER:

Indicates the presence of hazards that will cause severe personal injury, death or substantial property damage.



WARNING:

Indicates the presence of hazards that can cause severe personal injury, death or substantial property damage.



CAUTION:

Indicates presence of hazards that will or cause minor personal injury or property damage.



NOTICE:

Indicates special instructions on installation, operation or maintenance that are important but not related to personal injury or property damage.

Abbreviations

AB	=	Automatic Bypass
AV	=	Air Vent
BCT	=	Buderus cylinder thermostat
BDV	=	Buderus diverter valve
CB	=	Connector Block
CH	=	Central Heating
CHF	=	Central Heating Flow
CHR	=	Central Heating Return
CT	=	Cylinder Thermostat
CWDO	=	Condensate water drainage outlet
DV	=	Diverter Valve
E	=	Earth
L	=	Live
LSV	=	Lock Shield Valve
MCW	=	Mains Cold Water
N	=	Neutal
JB	=	Junction Box / RTH Converter
PL	=	Permanent Live
Prog	=	Programmer
PRV	=	Pressure relief valve (safety valve)
RT	=	Room Thermostat
RV	=	ModuLink 250 RF Receiver
T	=	Timer
TRV	=	Thermostatic Radiator Valve
WC	=	Wiring Centre
ZV	=	Two Port Zone Valve

1 Installation

1.1 Technical specifications

Dimensions	Unit	500 Series wall-mounted condensing gas system boiler
		500 - 24/S
Type of gas supply as established in EN 437 (GB/IE)		GB/IE II _{2H3P} 20 mbar, 37 mbar (natural gas H and LPG)
Rated thermal load for heating	kW	5.7 - 23.0
Rated thermal load for preparing hot water	kW	5.7 - 28.5
Rated heating capacity for system temperature (modulating from 30° to 100°)		
Heating curve 75/60 °C	kW	5.3 - 22.0
Heating curve 40/30 °C	kW	6.0 - 24.0
Seasonal efficiency (SEDBUK) for natural gas	%	90.3
for LPG	%	92.3
Max. gas rate for heating	m ³ /h	3.02
Max. gas rate preparing hot water	m ³ /h	2.43
Central heating installation		
Heating water temperature	°C	30 - 80
ΔT at residual head of 200 mbar	°C	< 20
Max. operating pressure of boiler	bar	3.0
Pump over run time	min	5
Expansion vessel		
Capacity of expansion vessel	l	7.5
Admission pressure of expansion vessel	bar	1.0
Pipe connections		
Gas on installation frame (compression fitting)	Ø mm	22
CH flow/return (compression fitting)	Ø mm	22
MCW inlet / DHW outlet (compression fitting)	Ø mm	15
Condensate water outlet	Ø inch	1
Pressure relief valve (compression fitting)	Ø mm	15 (adapter supplied with boiler)

1 Installation

Dimensions	Unit	500 Series wall-mounted condensing gas system boiler
		500 - 24/S
Flue gas values		
Condensate water quantity, natural gas, 40/30 °C	l/h	1.6
Exhaust-fume mass-flow rate		
Full load	g/s	10.6
Part-load	g/s	4.3
Exhaust-fume temperature, full load		
Heating curve 75/60 °C	°C	77
Heating curve 40/30 °C	°C	55
Exhaust-fume temperature, partial load		
Heating curve 75/60 °C	°C	60
Heating curve 40/30 °C	°C	35
CO ₂ full load, natural gas standard test gas G20	%	9.2
CO ₂ full load, natural gas standard test gas LPG	%	10.3
Standard emission factor CO	mg/kWh	<22
Standard emission factor NO _x	mg/kWh	<30
Flow pressure available for use	Pa	75
Flue-gas system		
Type of exhaust-fume connection		C _{13(X)} , C _{33(X)} , C _{53(X)} , C _{73(X)}
Diameter of flue gas system	mm	60/100 (accessory)
Electrical data		
Mains connection voltage	V	230 (50 Hz)
Electrical power consumption		
Full/Partial load	W	110/88
Electrical protection rating		IP X4D
Boiler dimensions and weight		
Height x Width x Depth	mm	780 x 460 x 330
Weight (without casing)	kg	31
Casing	kg	3

1.2 Dimensions, connections and assembly

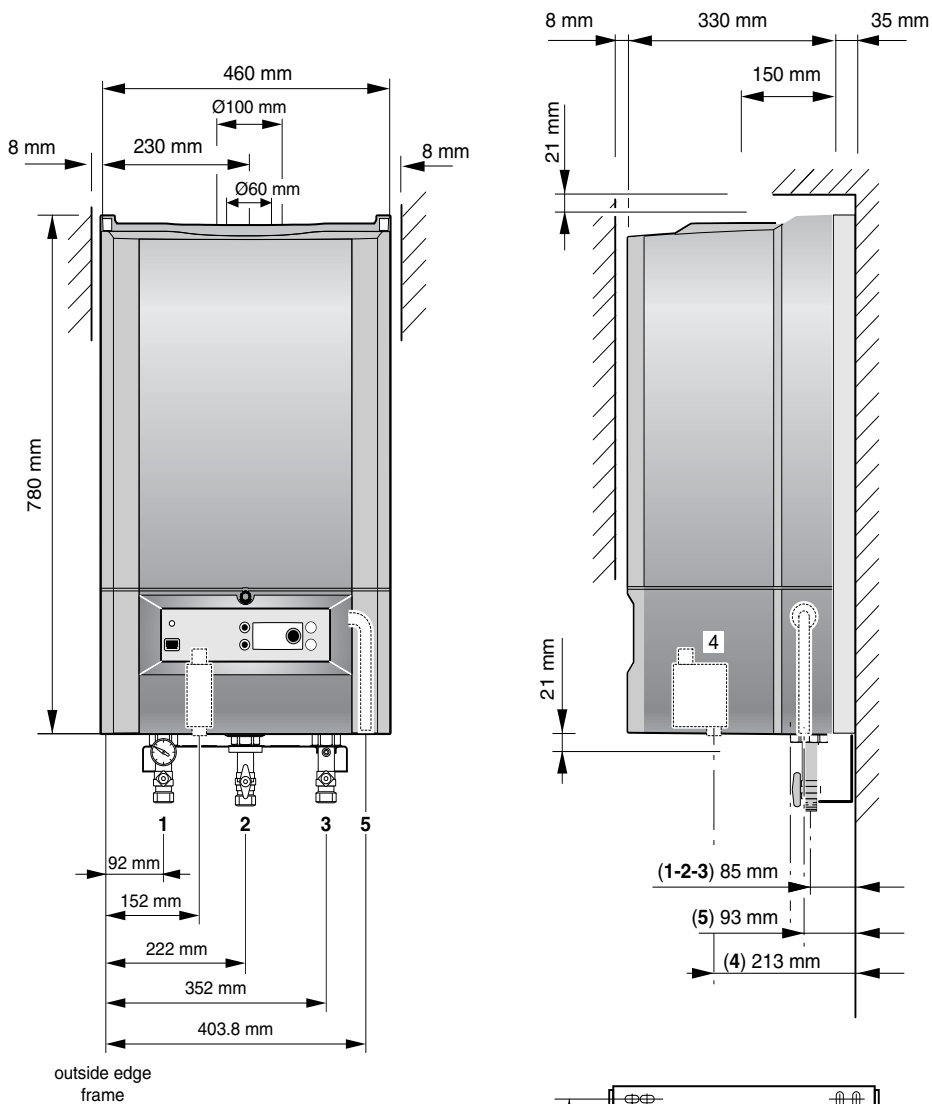

1. CH flow = $\text{Ø} 22\text{ mm}$ (compression fitting)
2. Gas = Gas connection $\text{Ø} 22\text{ mm}$ (compression fitting)
3. CH return = $\text{Ø} 22\text{ mm}$ (compression fitting)
4. CWDO = Condensate water drainage outlet $\text{Ø} 1''\text{ O/D}$
5. PRV = Pressure relief valve $\text{Ø} 15\text{ mm}$ (compression fitting)



NOTE

See wall-mounting template for the necessary clearances. The wall spacing frame may not always be necessary.

1 Installation

1.3 Items supplied with unit

- Check the contents against the packing list to ensure that nothing is missing.

Requirements to be met by the place of installation



NOTE

Observe all statutory building regulations applying to the place of installation.



DANGER!

Inflammable materials or liquids must not be stored or used near wall-mounted condensing gas boilers. The site of installation must be frost-protected.

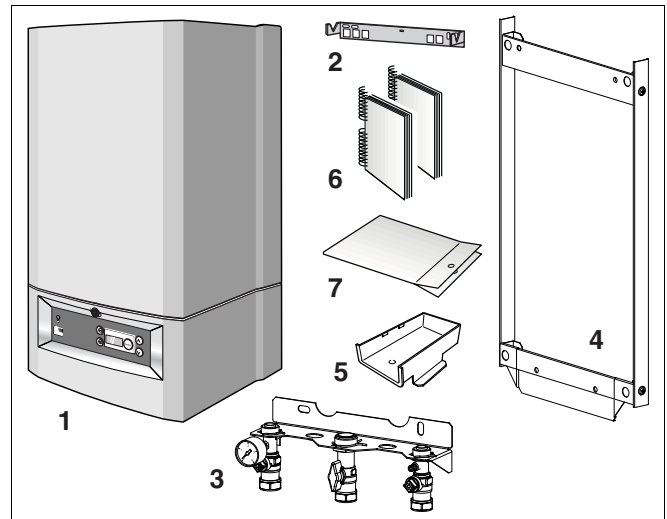

fig. 1 Items supplied with unit

Key to fig. 1:

- 1: Wall-mounted condensing gas system boiler
- 2: Wall bracket
- 3: Manifold Assembly
- 4: Wall spacing frame
- 5: Bracket for ModuLink 250 RF
- 6: Technical documents:
 - 1 x Installation and maintenance manual
 - 1 x User manual
 - 1 x Wall mounting template
 - 1 x Benchmark Logbook
 - 1 x Warranty card
 - 1 x Wall spacing frame instruction
 - 1 x Envelope for Warranty card
- 7: Plastic bag containing the following accessories:
 - 4 x wall fixing screws
 - 4 x wall plugs
 - 4 x washers
 - 8 x fixing screws for wall spacing frame
 - Seals (1 x G $\frac{1}{2}$ " - 1", 2 x $\frac{3}{4}$ " - 22 mm, 2 x $\frac{1}{2}$ " - 15 mm)
 - Initial start-up sticker
 - Second identification plate
 - Pressure Relief Valve compression fitting + pipe
 - Radiator key

1.4 Hanging the boiler



NOTE

Refer to manual of the wall spacing frame, which is supplied with the unit, for the correct mounting instructions when using a wall spacing frame.



CAUTION

DO NOT remove the polystyrene foam bottom slab until lifted into position. During installation work, cover the wall-mounted condensing gas boiler and the flue gas adapter to prevent site dirt from entering.

- Hang the wall mounting template.
- Drill the necessary holes.

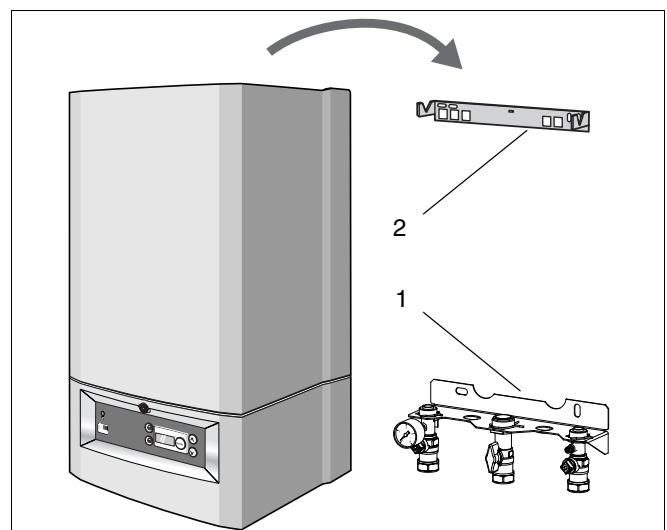

fig. 2 Installation

- Attach the manifold assembly to the wall (fig. 2, item 1).
- Make the pipework connections to the manifold.
- Attach the wall bracket (fig. 2, item 2).
- Open the locking mechanism using a radiator key (fig. 3, item 1). The radiator key is included in the delivery of the boiler in the accessories bag.
- Detach the casing of the condensing gas boiler (fig. 3).
- Remove the polystyrene foam piece from the top of the boiler.
- Hang the condensing gas boiler onto the wall bracket (fig. 2).



NOTE

If the boiler isn't connected to the pipework immediately, place caps on the pipe connections.

- Connect manifold unions to the boiler.

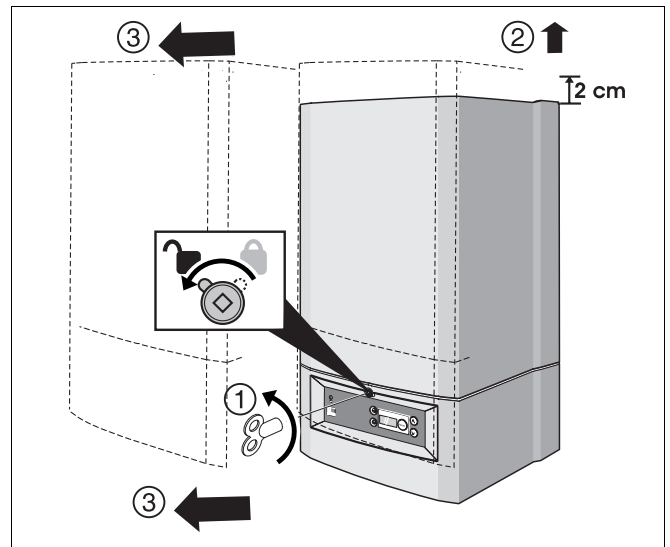

fig. 3 Remove casing

1.5 Water circulation system

The central heating system should be installed in accordance with **BS.6798** and, in addition, for smallbore and microbore systems, **BS.5449** or EN 12823.

1.6 Pipe connections

Pipework from the boiler is routed downwards as standard, but may be routed upwards behind the boiler using the wall spacing frame (supplied with the boiler).

- Connect pipes as shown in fig. 4. Ensure that all pipework is routed so as to minimise any strain on the boiler fittings.

Buderus advises to use copper piping for the first 600 mm, then it is allowed to switch to another approved pipe material.



CAUTION!

Do not use galvanised radiators or pipes.

1.6.1 Gas Supply

The gas installation must be installed in accordance with **BS.6891**.



CAUTION!

Pipework from the meter to the boiler **MUST** be of adequate size, generally at least $\text{Ø}22$ mm.

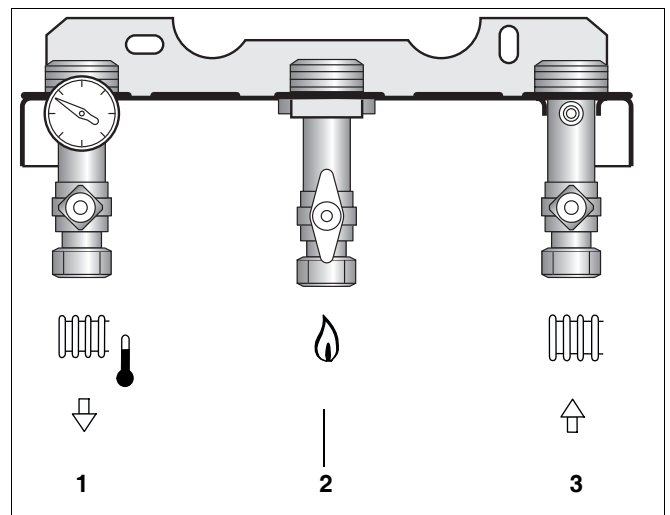

fig. 4 Pipe connections

Key to fig. 7:

- 1: CH flow
- 2: Gas
- 3: CH return

The complete installation **MUST** be tested for gas tightness and purged as described in **IGE/UP/1b**.

1.6.2 Gas connection

- Connect to gas supply according to relevant standards.

1.6.3 Compression fitting pressure relief valve outlet

- Insert the small piece of pipe (fig. 5).
- Attach the compression fitting (fig. 6).

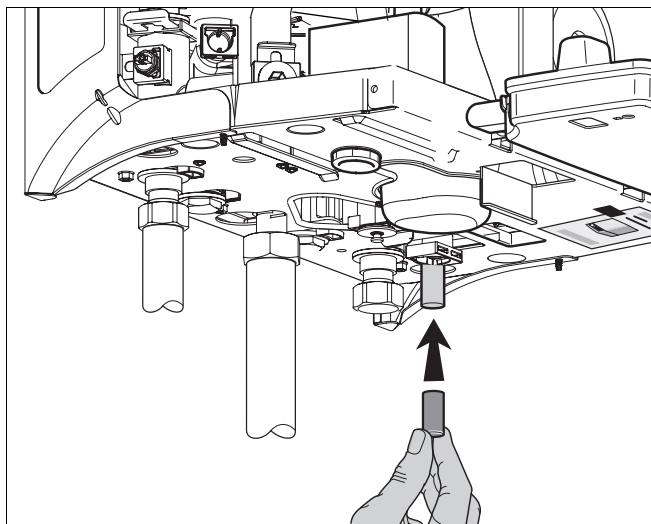

fig. 5 Insert pipe

1.6.4 Hot-water temperature



CAUTION!

DO NOT use galvanised pipes or fittings. The hot water heat exchanger is made of copper and is liable to suffer the effects of electrolytic corrosion.



NOTE

When using plastic pipes, observe the supplier's instructions - especially those referring to recommended jointing techniques and the notes relating to the heating system water on page 5.

- Connect pipes free of strain (fig. 4).

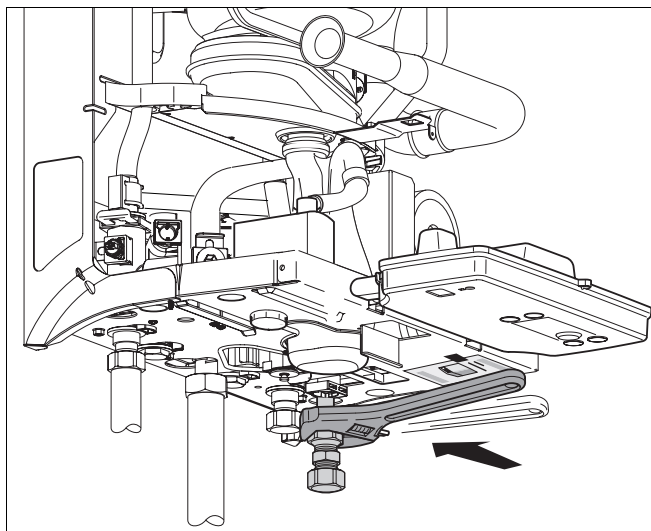

fig. 6 Compression fitting

1.6.5 Condensate removal

Positioning and termination of the condensate drain pipe

The condensate pipe should be run and terminate internally to the house soil and vent stack or waste pipe. Alternatively, the condensate can be discharged into the rainwater system if connected to a foul water draining system, or into a purpose-made soak away (condensate absorption point).

All connecting drainage pipework should generally have a fall of at least 2.5° to the horizontal, or approximately 50 mm per metre of pipe run. If this is can not be achieved, consider the use of a condens pump.

If an external pipe run is unavoidable then the run should be insulated with water proof insulation limited to 3 m in length. Should this be exceeded then the pipework diameter should be increased to 32mm and the pipework insulated using weather proof materials.



WARNING!

Any external run must be insulated with water proof insulation.

It should be noted that the connection of a condensate pipe to a drain may be subject to local building controls.

Material for condensate



NOTE

Ensure that the condensate trap is filled with water.

The condensate drainage pipe should be run in a standard drain pipe material, e.g. PVC (polyvinyl chloride), PVC-U (unplasticized polyvinyl chloride), BS (acrylonitrile-butadienes-tyrene), PP (polypropylene polypropylene) or PVC-C (cross-linked polyvinyl chloride).

The condensate drain can be attached to the syphon (fig. 7).

Any internal pipework should be of a diameter to match the requirements of the condensate exit pipe on the appliance.

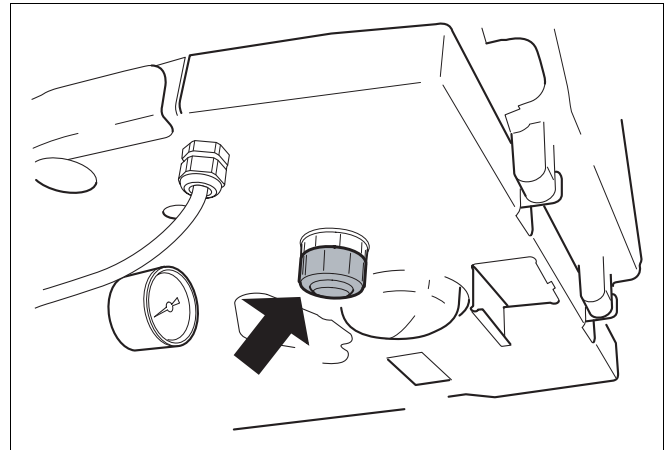

fig. 7 Condensate outlet

Internal termination to internal stack

The condensate drainage pipe should have a minimum outside diameter of 1" with no length restriction. It should incorporate a trap with a 75 mm condensate seal and be connected to the stack at a point at least 450 mm above the invert of the stack. **The trap built into the boiler will provide this 75 mm (fig. 8) condensate seal.**

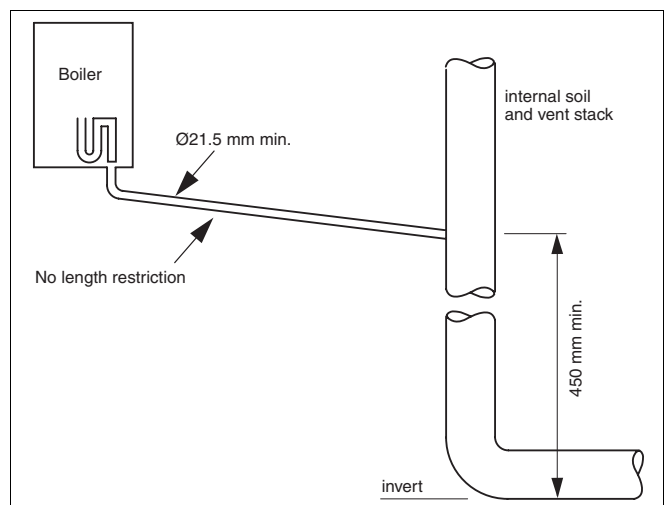

fig. 8 Internal termination of condensate drainage pipe to internal stack

External termination via internal branch (e.g. sink waste)

The condensate drainage pipe should have a minimum outside diameter of 1" with no length restriction. The connection should preferably be made downstream of the sink waste trap. If the connection is only possible upstream, then the air break is needed between the two traps. This is normally provided by the sink waste pipe (see fig. 9 and 10).

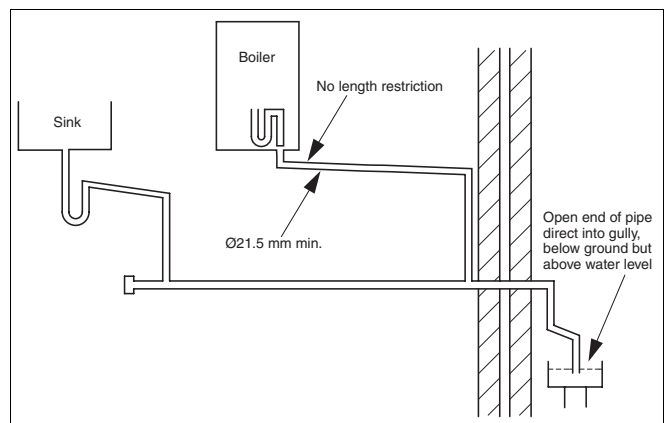

fig. 9 External termination of condensate drainage pipe via internal discharge branch (e.g. sink waste) and condensate syphon

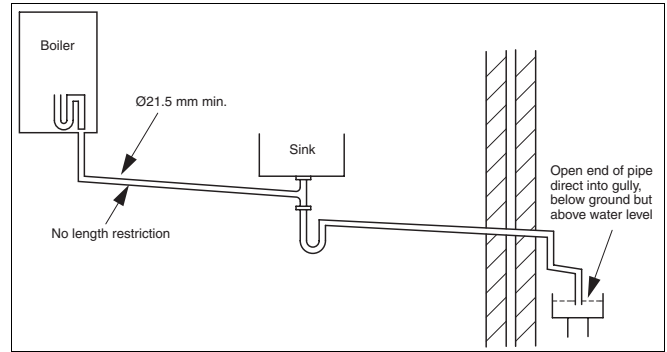

fig. 10 External termination of condensate drainage pipe via internal discharge branch (e.g. sink waste – proprietary fitting) and condensate syphon

Condensate absorption point

The condensate drainage pipe should have a minimum outside diameter of 1" and the external pipe length should not be more than 3 m. The condensate absorption point should be sited in a convenient position as close as possible to the boiler but not in the vicinity of other services. See fig. 11 for information.



NOTE

When discharging condensate to an outside drain caution must be taken to ensure blockage cannot occur during freezing conditions. If this is likely to occur, the use of a syphon trap is recommended.

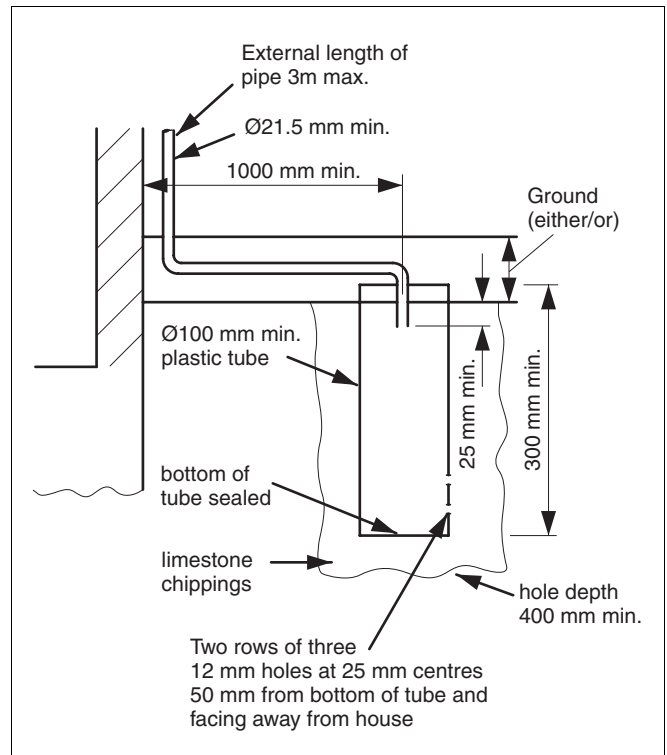

fig. 11 External termination of condensate drainage pipe to absorption point

1.7 Flue Installation

1.7.1 Siting the flue terminal

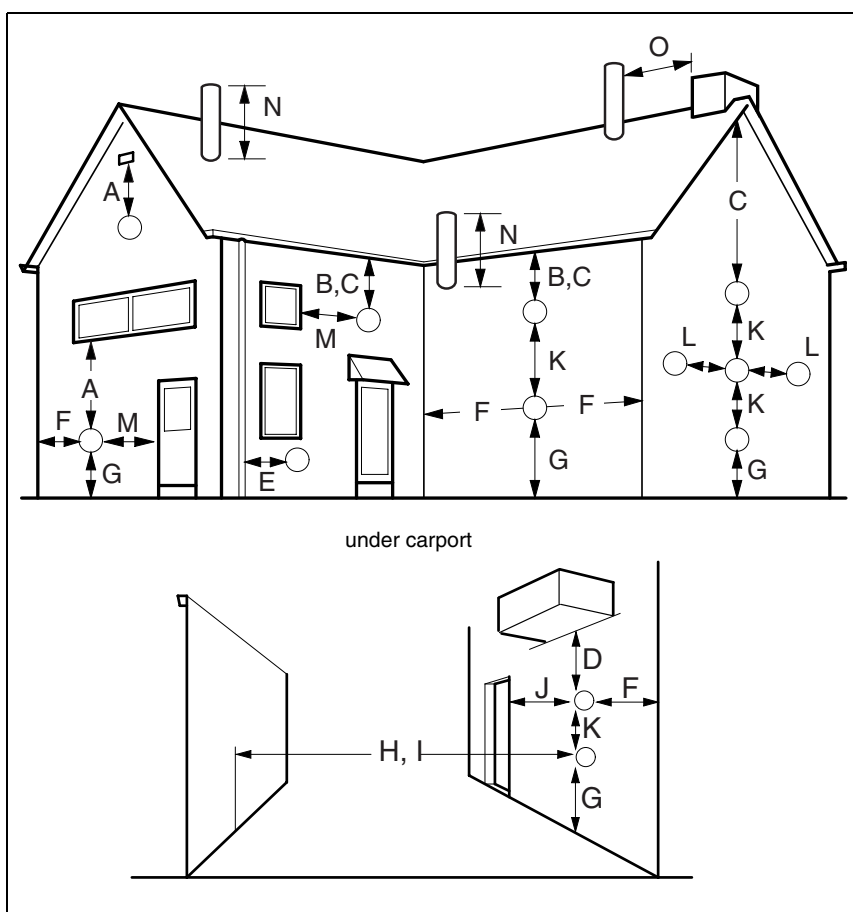

fig. 12 Flue terminal position

Terminal Position	Minimum Spacing
A. Directly below, above or alongside an opening window, air vent or other ventilation opening	300 mm
B. Below guttering, drain pipes or soil pipes	200 mm
C. Below eaves	200 mm
D. Below balconies or a car port roof Not recommended!	200 mm
E. From vertical drain pipes or soil pipes	150 mm
F. From internal or external corners	300 mm
G. Above adjacent ground, roof or balcony level	300 mm
H. From a surface facing the terminal	600 mm
I. From a terminal facing a terminal	1200 mm
J. From an opening in a car port (e.g. door or window) into dwelling. Not recommended!	1200 mm
K. Vertically from a terminal on the same wall	1500 mm
L. Horizontally from a terminal on the wall	300 mm
M. Adjacent to opening	300 mm
N. Above intersection with roof	300 mm
O. From a vertical structure on the roof	500 mm

table 1 Balanced flue terminal position

The flue must be installed in accordance with the recommendations of **BS. 5440-1:2000**.

Plumbing will occur at the terminal so terminal positions where this could cause a nuisance should be avoided.

The air supply and the flue gas exhaust must meet the applicable general regulations. Please consult the instructions provided with the flue terminal kits prior to installation.

The boiler **MUST** be installed so that the terminal is exposed to external air.

It is important that the position of the terminal allows the free passage of air at all times.

1 Installation

Minimum acceptable spacing from the terminal to obstructions and ventilation openings are specified in table 1.

If the lowest part of the terminal is less than 2 metres above the level of the ground, balcony, flat roof or place to which any person has access, the terminal must be protected by a guard.

Ensure that the guard is fitted centrally.

The flue assembly shall be so placed or shielded as to prevent ignition or damage to any part of the building.

The air inlet/products outlet duct and the terminal of the boiler MUST NOT be closer than 25 mm to combustible material. Detailed recommendations on the protection of combustible material are given in **BS. 5440- 1:2000**.



NOTE

It is absolutely essential to ensure, in practice, that products of combustion discharging from the terminal cannot re-enter the building or any other adjacent building through ventilators, windows, doors, other sources of natural air infiltration, or forced ventilation/air-conditioning.

If this could occur the appliance MUST be turned off (with the owners permission), and labelled as unsafe until corrective action can be taken.



DANGER!

Only use Buderus flue gas systems. As other flue gas systems are not tested with this appliance.

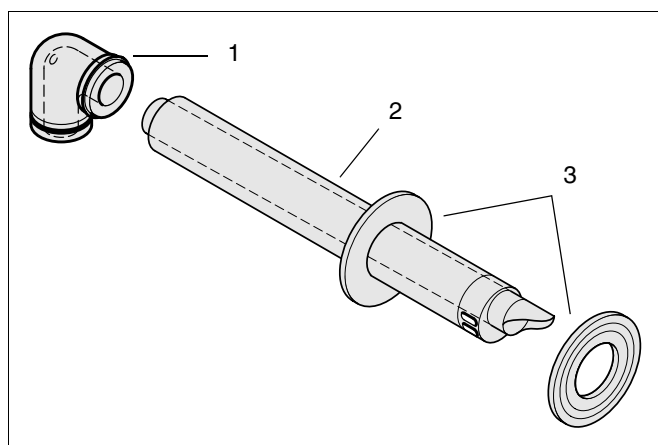

fig. 13 Standard horizontal flue pack

1.7.2 Air supply and flue gas exhaust in a closed installation

A ventilation cover is integrated into the 500 Series condensing gas system boilers. This cover houses a number of components, such as the burner and the heat exchanger. Since this ventilation cover is part of the air supply system, it is vital that it is always installed correctly.

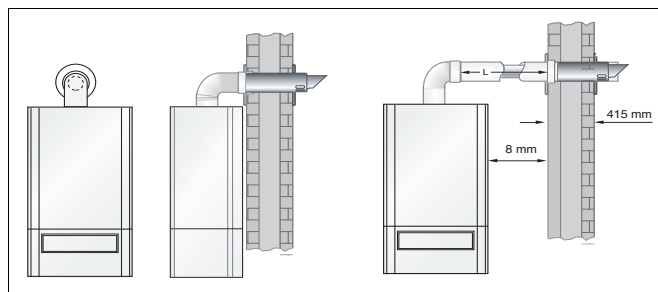

fig. 14 Side flue and rear flue installation

Standard horizontal flue pack (fig. 13):

- **item 1:** Flue turret 60/100;
- **item 2:** Horizontal flue terminal 60/100;
- **item 3:** Flue finishing kit.

To ensure optimal operation, the 500 Series appliances must be connected to a Buderus horizontal or vertical flue terminal. These terminals have been developed specifically for Buderus condensing gas boilers and have been comprehensively tested for trouble free operation when correctly installed.

Standard vertical flue pack (fig. 15):

- **item 1:** Vertical flue terminal 60/100.
- **item 2:** Weather collar
- **item 3:** Flue support bracket
- **item 4:** Vertical flue adaptor

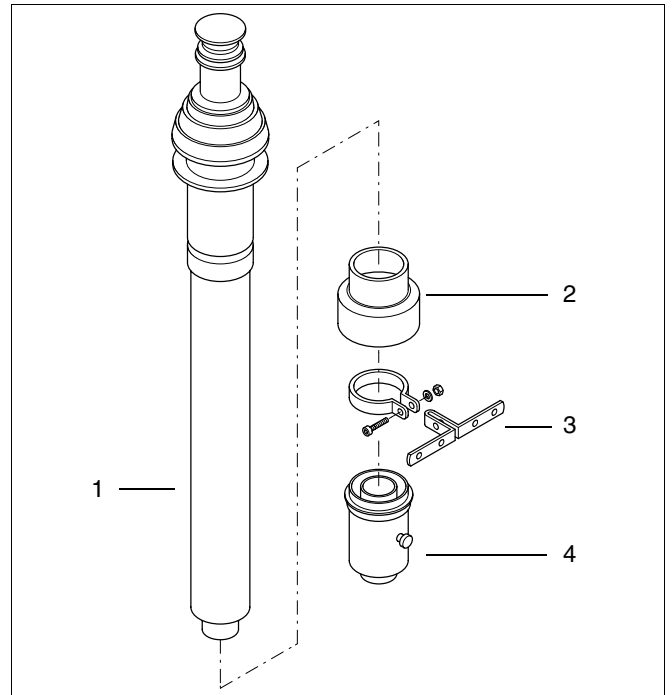

fig. 15 Standard vertical flue pack

1.7.3 Maximum Flue length (L)

The maximum pipe length (L) of the air supply and flue gas exhaust pipes for the 500 Series condensing gas system boilers is determined by the total pressure loss of all components in the flue gas exhaust / air supply system.

Maximum length of horizontal or vertical extensions for 60/100 flue system is L = 12 m. Maximum length of horizontal or vertical extensions for 80/125 flue system L = 35 m (see fig. 16 and fig. 17).

Take the flue pipe clearances into account when planning the layout of the place of installation (see subsection 1.7.1: "Siting the flue terminal" on page 15).

Maximum wall thickness without extensions is 415 mm. Maintain a minimum side clearance of 8 mm (see fig. 14).

Flow pressure available for use [Pa]	
Buderus 500 - 24/S	75

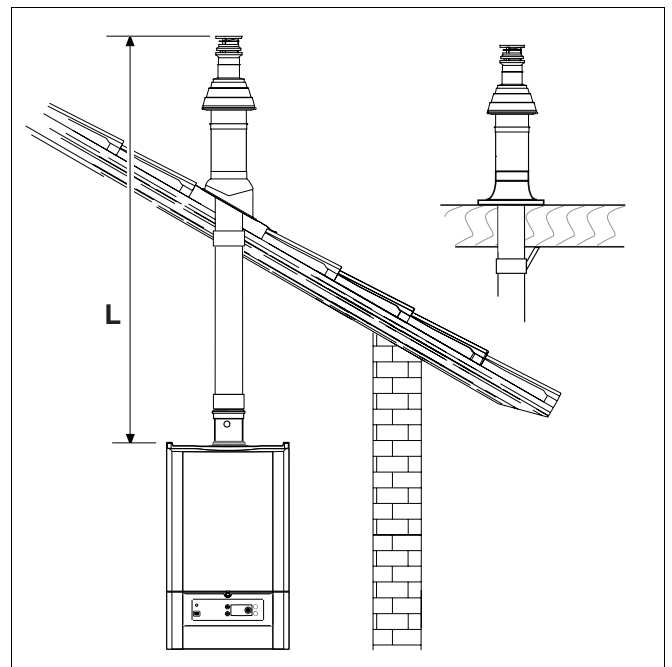





fig. 16 Vertical flue length

1 Installation

1.7.4 Additional flue parts

The additional flue parts listed can be ordered from your supplier.

Flue size 60/100:

60/100 flue system	For every bend or extension the max. flue length (L) has to be reduced by:
 500 mm extension	0.5 m
 1000 mm extension	1.0 m
 90° bend	1.4 m
 45° bend	0.7 m

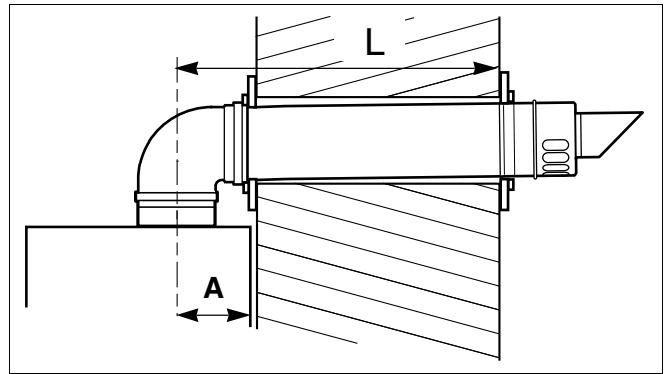





fig. 17 Horizontal flue length



NOTE

The total reduction length must never exceed the maximum flue length.

Flue size 80/125 (optional):

80/125 flue system	For every bend or extension the max. flue length (L) has to be reduced by:
 500 mm extension	0.5
 1000 mm extension	1.0
 90° bend	1.6
 45° bend	0.9



NOTE

Vertical adaptor (60/100 --> 80/125) is required for 80/125 flue gas systems, because the flue outlet of the boiler is 60/100.

Weathering slates for 60/100 and 80/125

Flat roof, pitched roof.

1.7.5 Standard 100 mm flue systems

The standard concentric flue system provides for a max. horizontal straight length of upto 12.0 m for 60/100 flue connection (see subsection 1.7.3).

Full instructions for fitting this flue are in subsection 1.7.8: "Installation of the horizontal flue" on page 20.



IMPORTANT

Any horizontal flue system fitted to a condensing boiler must be inclined towards the appliance at an angle of 30 mm per metre length to prevent condensate dripping from the flue terminal.

This means that the clearance above the appliance must be increased to match the duct length. See figure on page 9.



NOTE

When using a wall spacing frame, don't forget to take its measurements into account when designing a flue system.

1.7.6 Connecting the vertical flue adaptor

- Fit the vertical flue adaptor (fig. 18) onto the appliance flue connector.

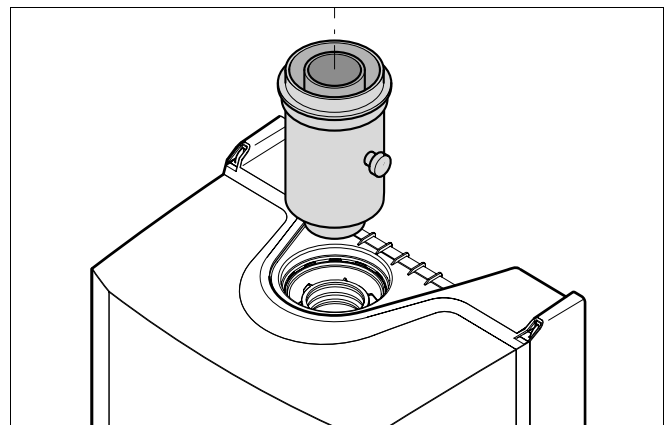

fig. 18 Vertical flue adaptor

1.7.7 Connecting the horizontal flue turret

- Fit the horizontal flue turret (fig. 19) onto the appliance flue connector.

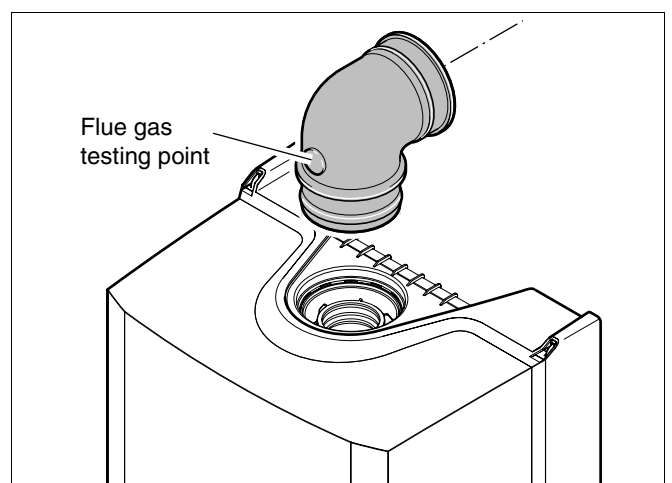

fig. 19 Horizontal flue turret with flue gas testing point

1 Installation

1.7.8 Installation of the horizontal flue

The standard flue is suitable for lengths up to 660 mm (see fig. 20). For longer flue runs up to 12.0 m, extension air/flue ducts are available.



NOTE

Use the wall-mounting template to help you mark the position of the side flue opening

1.7.9 Flue duct preparation and assembly

- Measure the flue length L. Refer to figures 21 and 22.



NOTE

The flue must be inclined from the boiler.

- Mark off the lengths shown onto the ducts and cut the length. The cuts must be square and free from burrs. Terminal assembly outer (air) duct - L-70 mm, inner (flue) duct - L-50 mm. The measurement is made from the ridge at the terminal indicating the outer face of the wall. Refer to figure 23. Extension air duct - L-70 mm, flue duct - L-50 mm. The measurement is from the formed end.
- Assemble flue system completely. Push the ducts fully together. The slope of the terminal outlet must be face downwards (see fig. 23, item 1). The assembly will be made easier if a solvent free grease is lightly applied to the male end of the ducts.



NOTE

An inner flue finishing kit is provided which should be fitted to the ducts before assembly.

- Push the assembly through the wall and slide the turret onto the flue connector. Refer to figure 19. Ensure that the turret is fully entered into the socket on the boiler.
- From the outside fix the flue finishing kit to the terminal and, after ensuring the duct is properly inclined towards the boiler, fix the finishing kit to the wall. If the terminal is within 2 m of the ground where there is access then an approved terminal guard must be fitted. The guard must give a clearance of at least 50 mm around the terminal and be fixed with corrosion resistant screws.

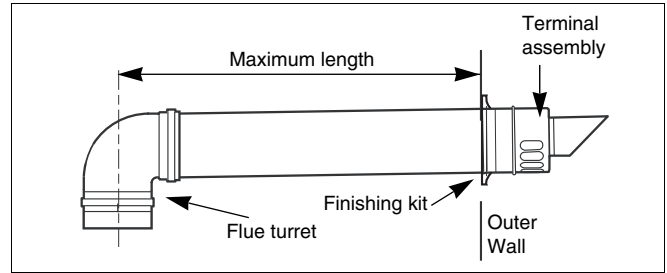

fig. 20 Installation with horizontal flue gas turret

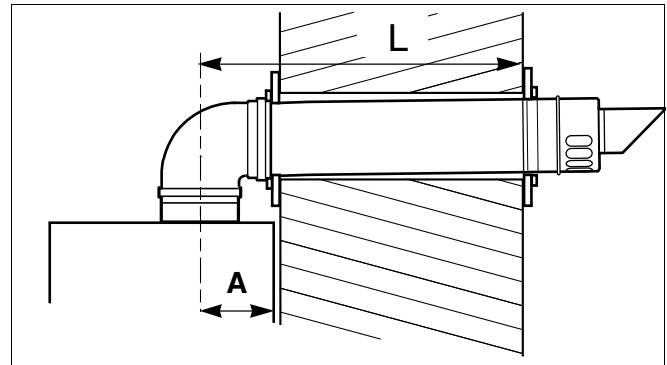

fig. 21 Flue length - rear

Item A = 150 mm without the use of a wall spacing frame
Item A = 185 mm with the use of a wall spacing frame

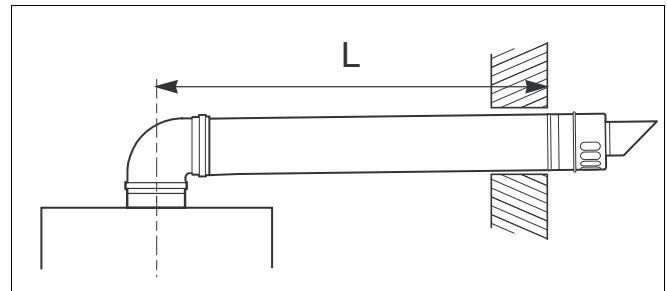

fig. 22 Flue length - side

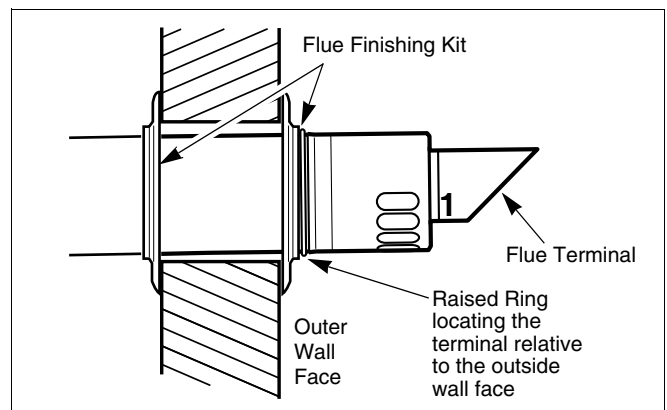

fig. 23 Flue terminal position

1.8 Electrical connections

1.8.1 Mains connection



NOTE

All Buderus boilers require a permanent live.

A mains supply of 230 V - 50Hz is required.

External controls are suitable for volt free or 230 V installation.

Wiring to the boiler **MUST** be in accordance with the current I.E.E. (**BS.7671**) Wiring Regulations and any local regulations.

Wiring should be a 3 core PVC insulated cable, not less than 0.75 mm² (24 x 0.2 mm), and to table 16 of **BS.6500**.

Connection must be made in a way that allows complete isolation of the electrical supply such as a double pole switch having 3 mm contact separation in both poles, or by a three pin connector, serving only the boiler and system controls. This boiler is equipped with a double pole switch see fig. 24, item 1. The means of isolation must be accessible to the user after installation.

The electrical connection to the mains supply should be readily accessible and adjacent to the boiler.

If the supply cord is damaged, it must be replaced by a registered Corgi installer to avoid a hazard and must be an original spare part.

The electrical supply for both the boiler and the system must be taken from the same fused spur outlet.

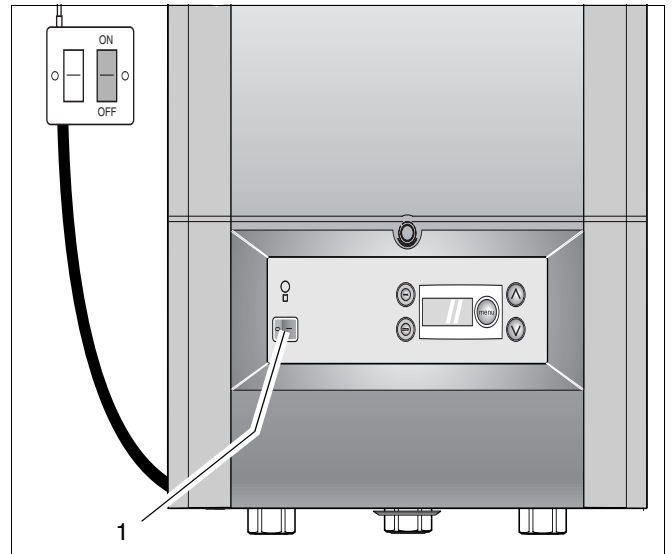

fig. 24 DBA



WARNING!

Do not connect 230V to the connection block on the back of the DBA.

1.9 DBA wiring diagram

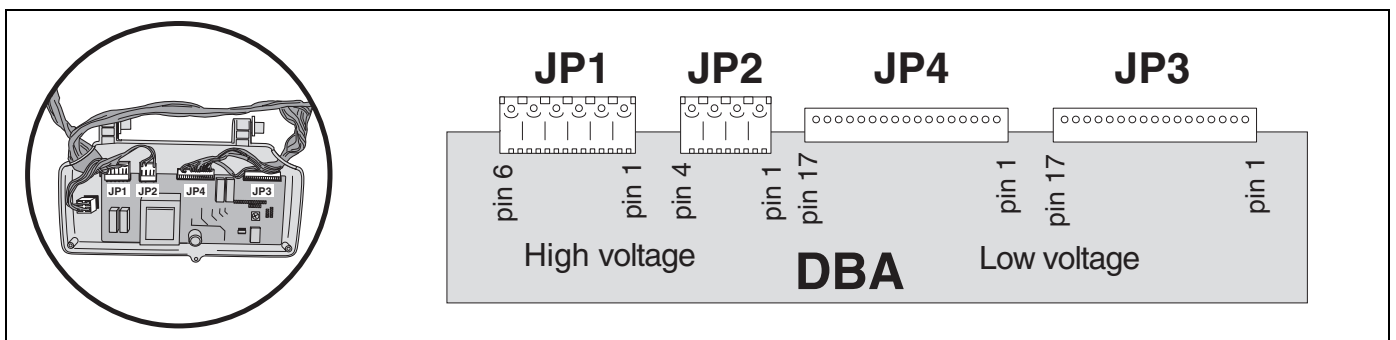

WARNING!

Do not connect 230V to the connection block on the back of the DBA.

1 Installation

1.10 Electrical wiring diagram

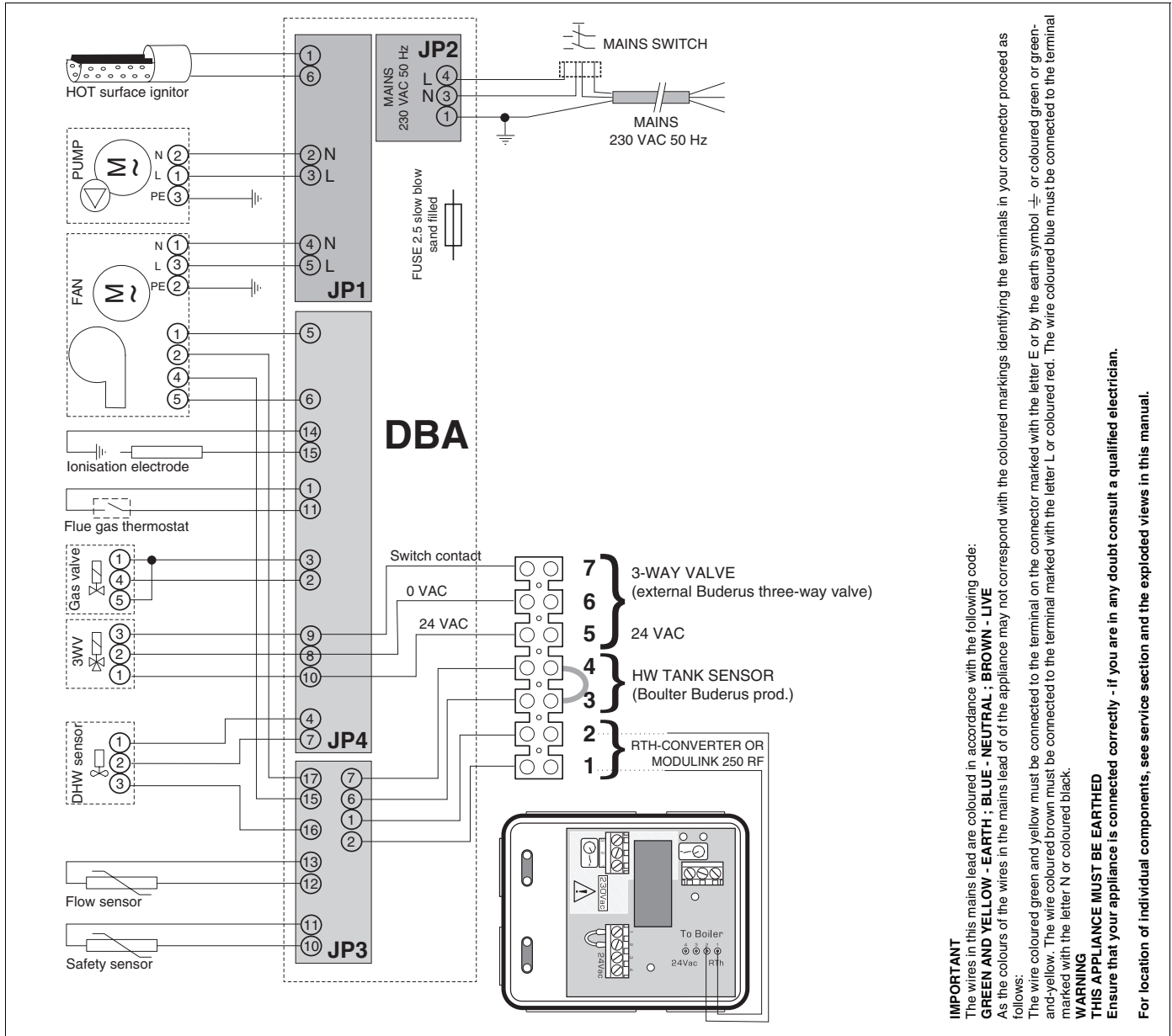

1.10.1 DBA connection block terminals

The possible terminals are (fig. 25):

- Terminal 1 and 2 are in use for the rth-converter or used for the ModuLink 250 RF thermostat.
- Terminal 3 and 4 are used for connecting a sensor for the hot water cylinder. **This is only for the Buderus 500-24/S** with an external hot water cylinder. Only remove the wire bridge when installing a hot water cylinder.
- Terminal 5, 6 and 7 are used for an external Buderus 3-way valve (see subsection 1.10: "Electrical wiring diagram" on page 22).



WARNING

DO NOT connect 230V to the DBA connections.

1.10.2 External 230V controls

The wall-mounted condensing gas system boiler can be fitted with the following external controls.

- a ModuLink 250 RF (see subsection 1.10.3) or other recommended Buderus 24V controls;
- a room-temperature control device at 230V connected to the rth-converter (see subsection 1.10.4, S-plan and Y-plan);
- or an ON/OFF temperature controller, volt free (see subsection 1.10.5).

1.10.3 ModuLink 250 RF connection

The ModuLink 250 RF thermostat modulates on room temperature.

The Buderus 500-24/S boilers work most efficient with Buderus thermostats. Therefore these thermostats are recommended by Buderus.



NOTE

See the instructions of the other Buderus thermostats for installation instructions.

Receiver bracket installation



NOTE

The receiver is not waterproof. Avoid water coming into contact with the receiver when servicing the boiler.

- Remove the casing of the receiver (fig. 26, item 1).

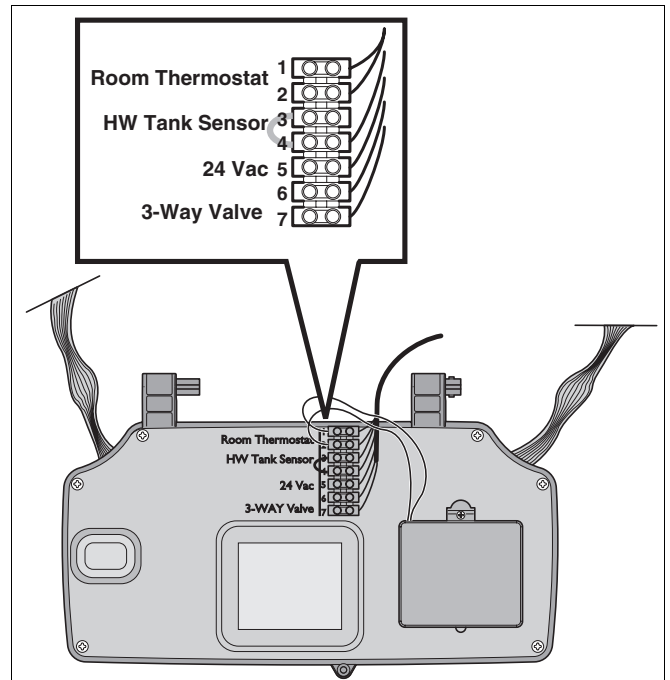

fig. 25 Connections backside DBA

item 1, 2: Buderus control

item 3, 4: Buderus cylinder valve

item: 5, 6, 7: Diverter valve

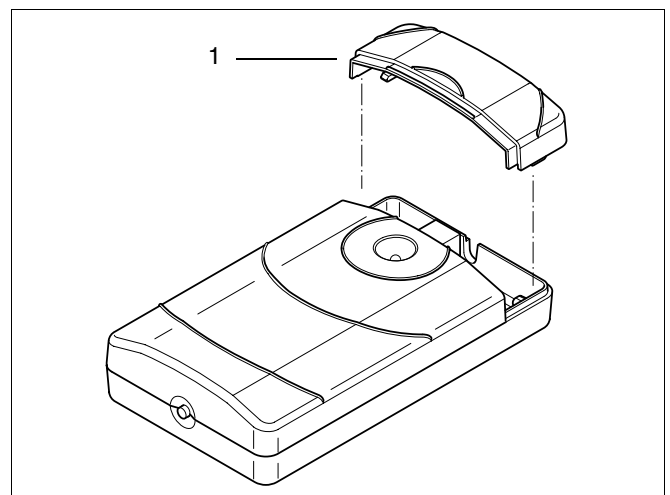

fig. 26 Receiver bracket

1 Installation

- Connect the thermostat's cable (supplied with the thermostat) to the receiver (fig. 27).
- Refit the casing (fig. 27, item 1).

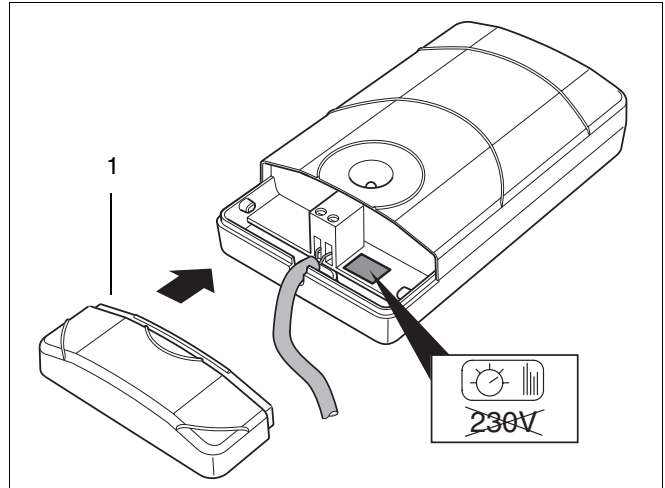

fig. 27 Connect cable

- Slide the receiver into the bracket (supplied with the boiler) so that it is secured (fig. 28).

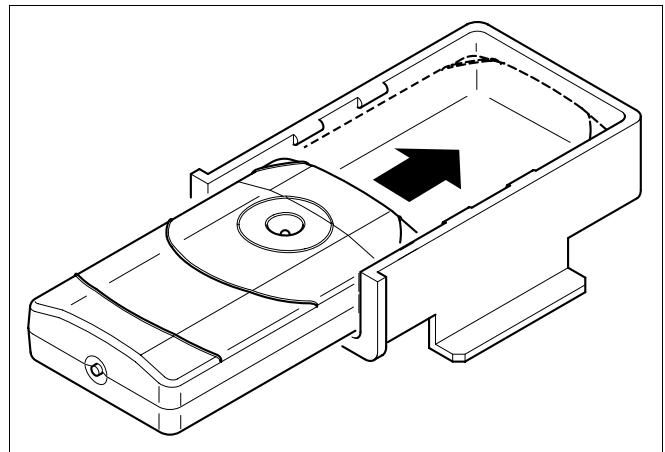

fig. 28 Place receiver into bracket

- Remove the boiler's casing.

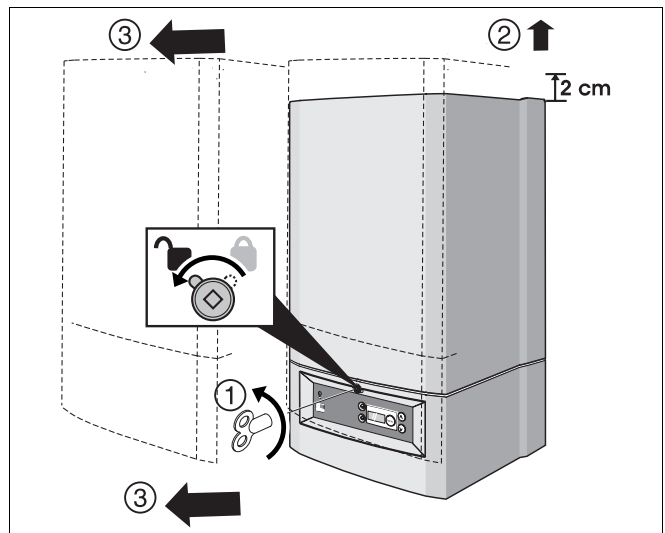

fig. 29 Remove casing

- Slide the receiver in the guide rails on the bottom part of the boiler (fig. 30).

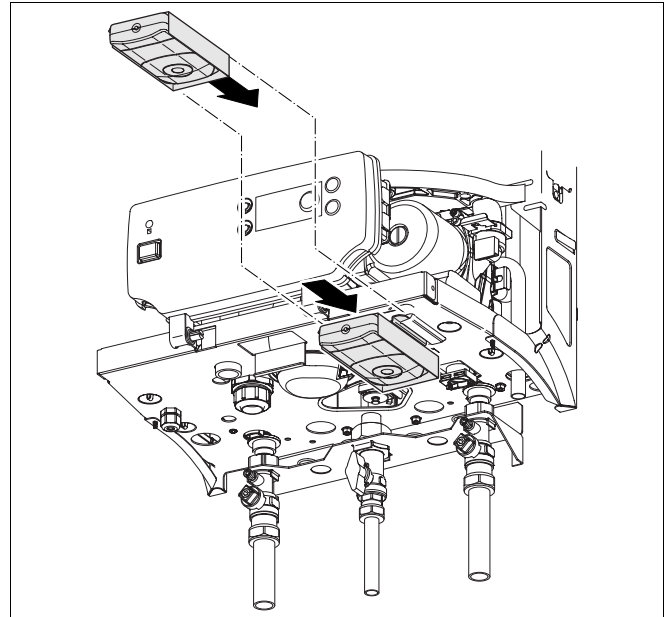

fig. 30 Place receiver

- Connect the black pre-wired lead to a permanent live supply (from the same fused isolator as all other controls on the heating system), L N E (fig. 24).
- Remove the securing screw of the DBA and lower the DBA (see fig. 31).

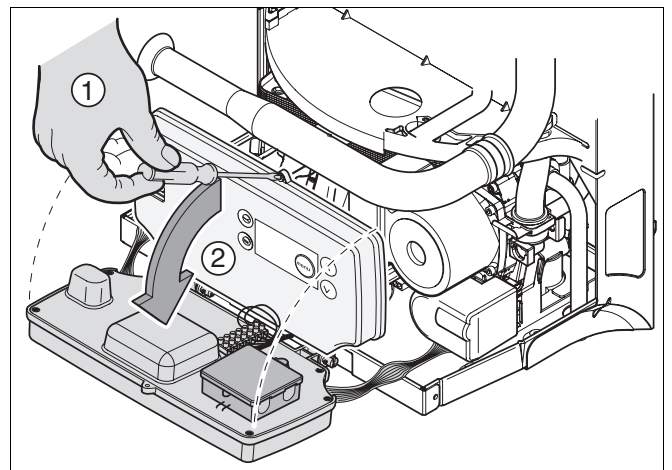

fig. 31 Lower the DBA

- Disconnect the twin cable of the rth-converter from terminal 1 and 2 of the connection block (see fig. 32, item 1) on the back of the DBA.
- Connect the cable of the ModuLink 250 RF receiver to terminal 1 and 2 of the room thermostat connection on the back of the DBA (see fig. 32, item 1).

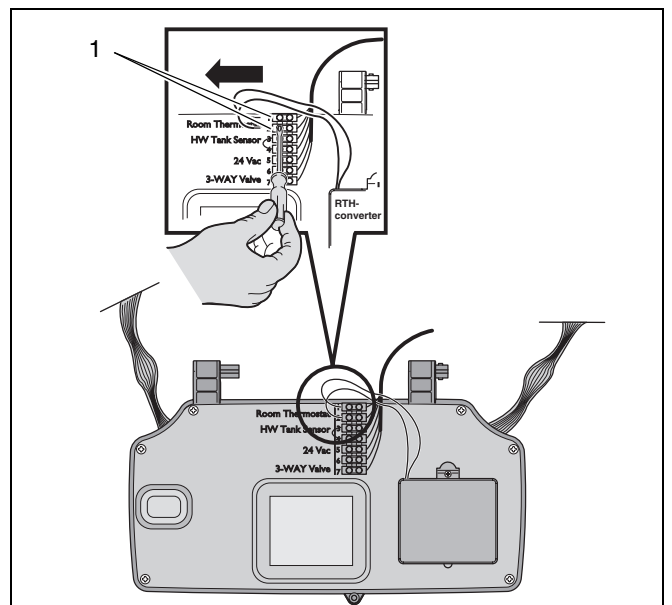

fig. 32 Room thermostat connection on DBA

1.10.4 External 230V controls (see also Y-plan and S-plan on page 28 and 29)"



WARNING!

This appliance must be earthed.

- Connect the black pre-wired lead to a permanent live supply (from the same fused isolator as all other controls on the heating system), L N E (fig. 24).
- Remove the securing screw of the DBA and lower the DBA (see fig. 31).
- Remove the cover of the rth-converter (fig. 33, item 1).
- Feed the 230V switch live and neutral (from external controls) through the cable gland.
- Identify the 230V terminal block by the shaded area and 230V label.
- Connect the switch live to terminal "1" and a neutral to terminal "2" (fig. 33, item 2).
- Replace covers.



NOTE

Terminal 3 (fig. 33, item 2) is not used.

1.10.5 Volt free external control device connection

- Connect the black pre-wired lead to a permanent live supply (from the same fused isolator as all other controls on the heating system), L N E (fig. 24).
- Remove the securing screw of the DBA and lower the DBA (see fig. 31).
- Remove the cover of the rth-converter (fig. 33, item 1).
- Lead the control device wire through the cable lead.
- Fix the wire to terminal 1 and 2 of the volt free connection (fig. 33, item 3).

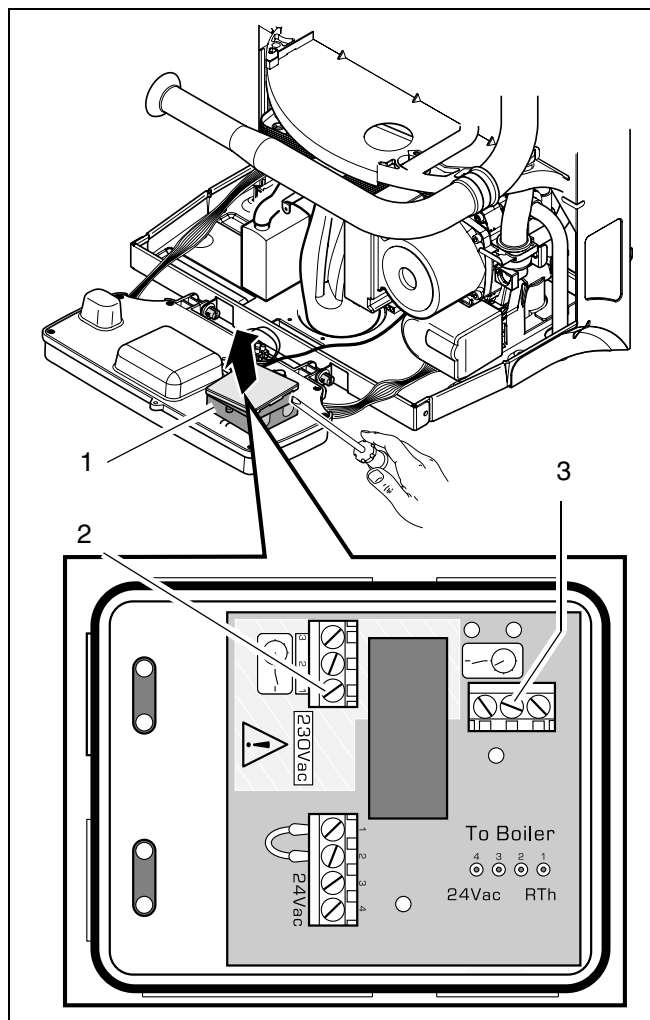

fig. 33 Connection box - 230 Volt and Volt free connection

1.11 System examples



NOTE

Example systems are to be regarded as schematic representations only.

Buderus 500-24S with ModuLink 250 RF or other Buderus controls

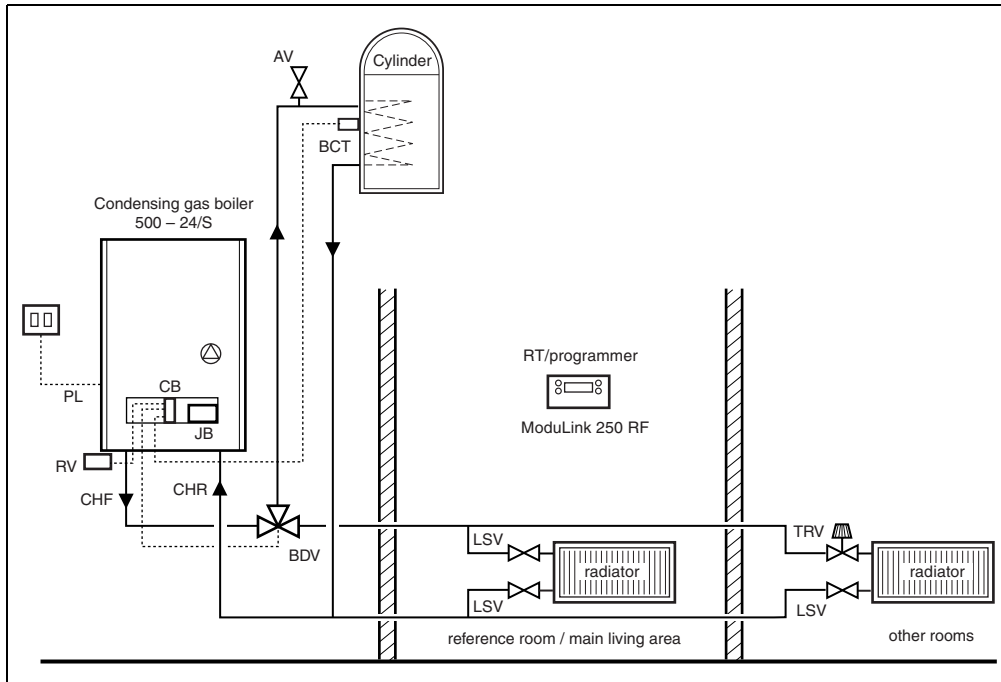

Key to abbreviations:

- AV = Air Vent
- BCT = Buderus cylinder thermostat
- BDV = Buderus diverter valve
- CB = Connector Block
- CHF = Central Heating Flow
- CHR = Central Heating Return
- JB = Junction Box / RTH Converter
- LSV = Lockshield Valve
- PL = Permanent Live
- RT = ModuLink 250 RF
- RV = ModuLink 250 RF Receiver
- TRV = Thermostatic Radiator Valve

fig. 34



CAUTION!

The BCT and BDV are Buderus products.

1 Installation

Buderus 500-24S with external 230V connection (Y-plan ; see fig. 35 and 36)

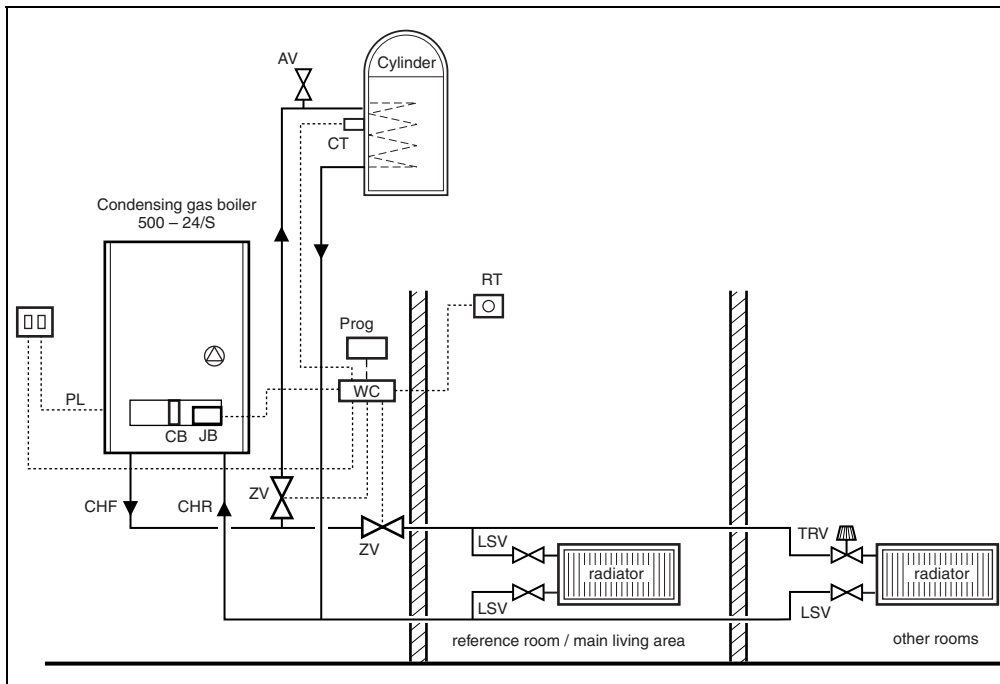

- Key to abbreviations:
- AV = Air Vent
 - CB = Connector Block
 - CHF = Central Heating Flow
 - CHR = Central Heating Return
 - CT = Cylinder Thermostat
 - DV = Diverter Valve
 - JB = Junction Box / RTH Converter
 - LSV = Lockshield Valve
 - PL = Permanent Live
 - Prog = Programmer
 - RT = Room Thermostat
 - TRV = Thermostatic Radiator Valve
 - WC = Wiring Centre

fig. 35

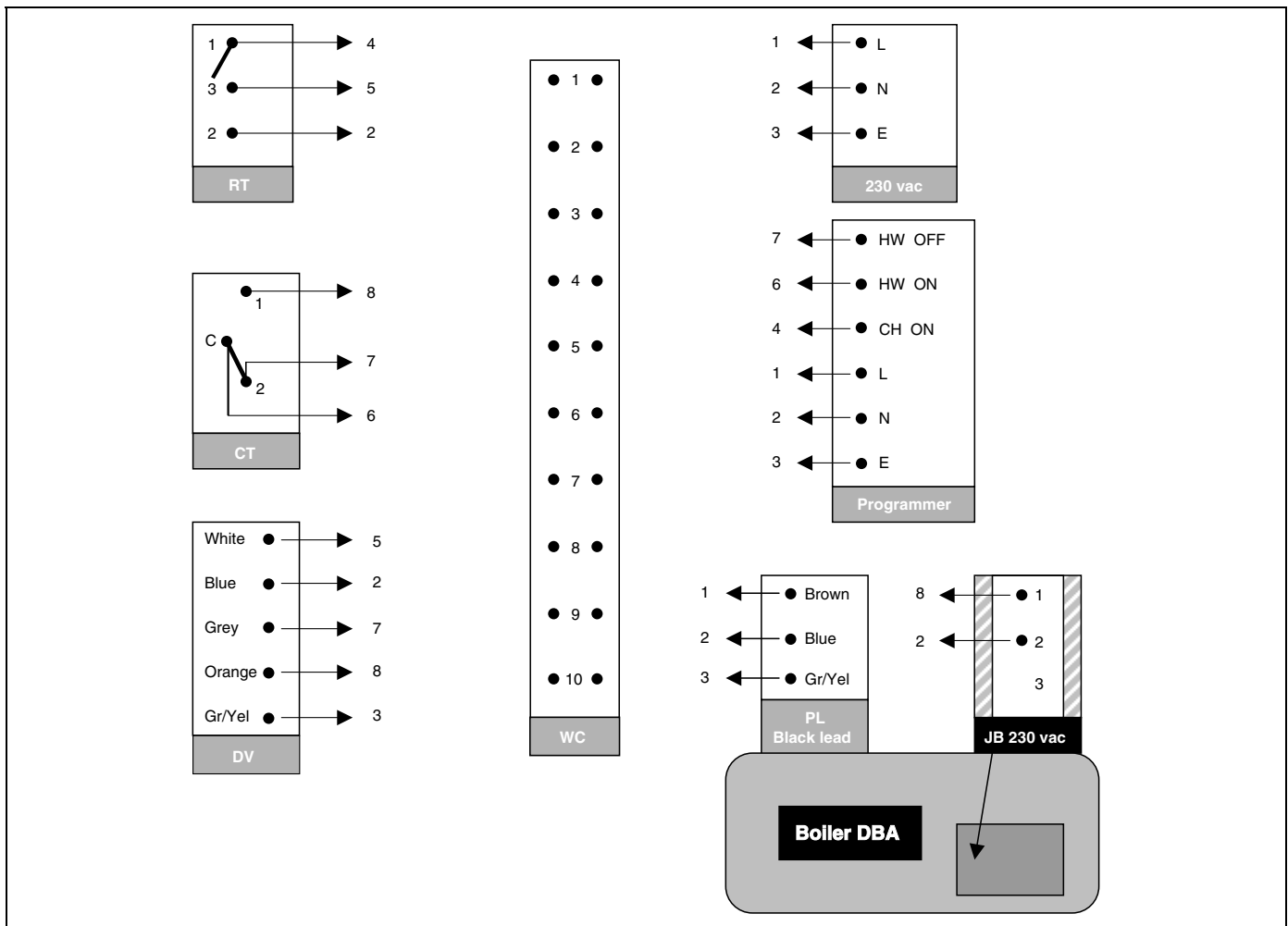
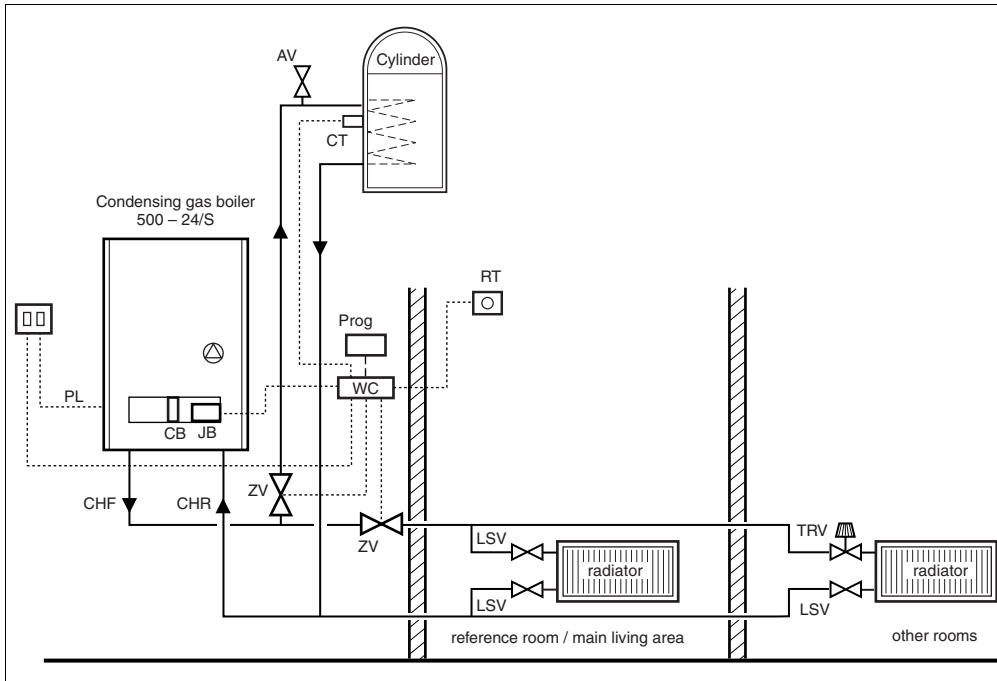

fig. 36 Wiring diagram Y-plan with external 230V controls

Buderus 500-24S with external 230V connection and two port zone valves (S-plan ; see fig. 37 and 38)



- Key to abbreviations:
- AV = Air Vent
 - CB = Connector Block
 - CHF = Central Heating Flow
 - CHR = Central Heating Return
 - CT = Cylinder thermostat
 - JB = Junction Box / RTH Converter
 - LSV = Lockshield Valve
 - PL = Permanent Live
 - Prog = Programmer
 - RT = Room thermostat
 - TRV = Thermostatic Radiator Valve
 - WC = Wiring Centre
 - ZV = Two port Zone Valve

fig. 37

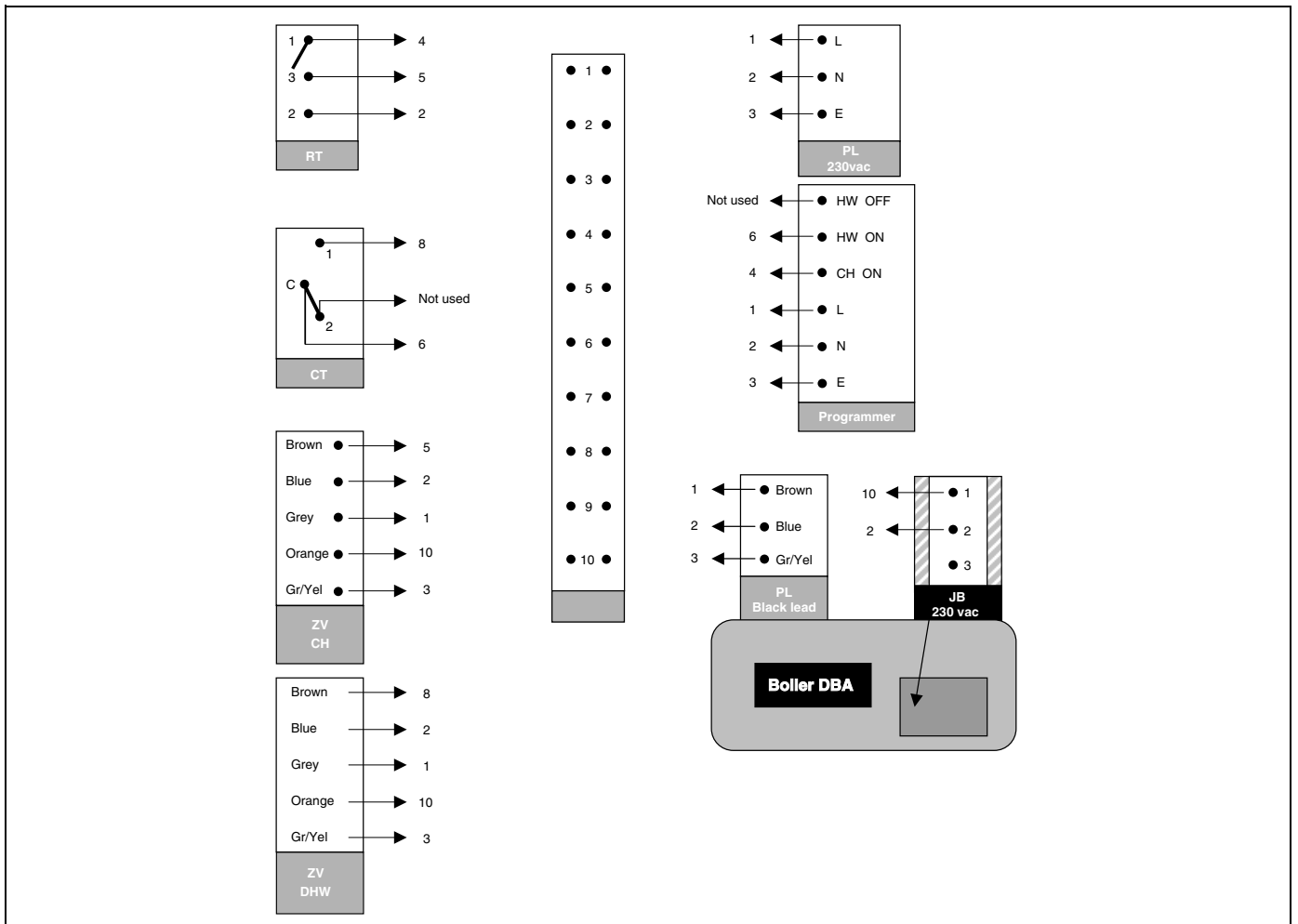

fig. 38 Wiring diagram S-plan with external 230V controls and two port zone valves

2 Commissioning

When a boiler starts up there are a couple of things that happen. Below is a short process description:

When there is a heat demand:

The fan starts up and the glow ignitor turns on.

When there is a DHW request then the three-way-valve switches from CH operation to DHW operation.

The pump starts up as soon as the three-way-valve is in the right position.

Once all the requirements are met (glow ignitor is hot enough, fan is operating at the correct speed and the pump is on) then the gas valve will open.

Now a flame may or may not develop, but the glow ignitor extinguishes. A flame will establish and the glow ignitor extinguishes. The operating controls are released once a flame is sensed. After a possible check, the boiler will deliver the requested output.

Should the flow check fail, the boiler will shut down for a short while and then try to start up again.

If no flame develops then the gas valve closes and the fan continues to run to post purge. The boiler will try to start up three times. If there still is no flame developing after three times, then the boiler will lock-out.

When the heat demand stops:

The gas valve closes.

The fan will keep going for a short while to post purge the appliance.

The pump will continue for a while to disperse any remaining heat energy from the boiler to the heating system.

If there has been a heat request then the three-way-valve will switch back to the central heating setting.

Follow the steps described in this chapter to properly commission the boiler and fill out the commissioning log book.



NOTE

If a fault occurs, then refer to the servicing manual or contact Buderus.

2.1 Preparing the boiler for operation



CAUTION

DO NOT operate the condensing gas boiler if large amounts of dust are present, e.g. due to building work in and around the place of installation.

2.1.1 Fill the heating system



WARNING!

The wall-mounted condensing gas system boiler must not be activated at this stage.

- Loosen the automated air vent one turn (fig. 39).

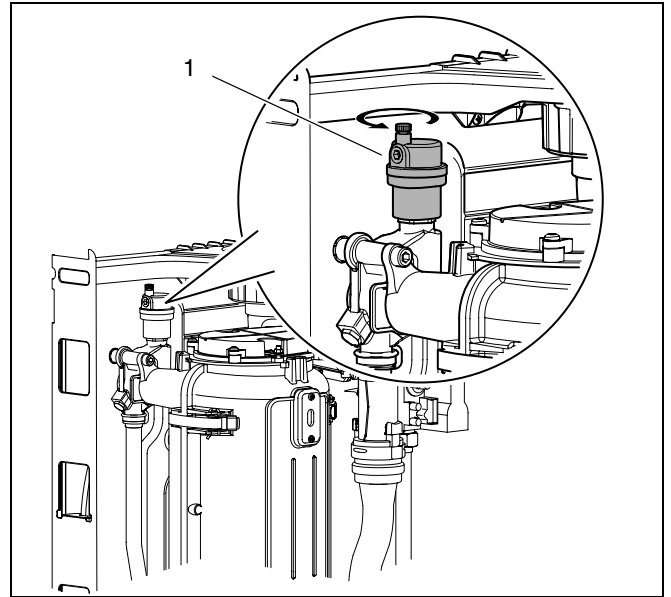

fig. 39 Automatic air vent

- If necessary open the CH flow and CH return servicing valves (fig. 40, item 1 and 2).

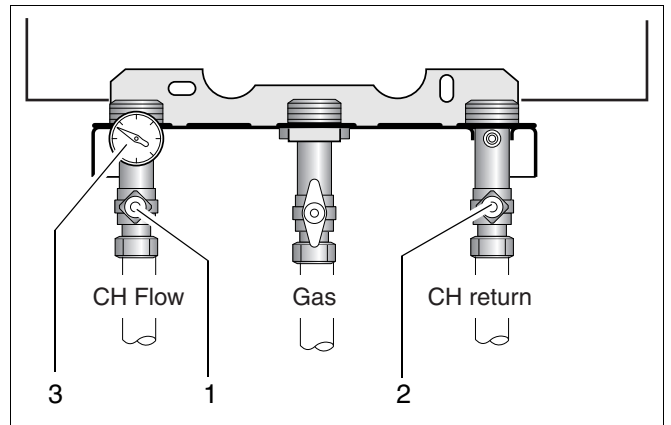

fig. 40 servicing shut off valves

- Connect filling loop (fig. 41).
- Open both stop valves (fig. 41).
- Fill the system to a pressure of approx. 1.5 bar (fig. 40, item 3).
- Shut both stop valves.
- Disconnect the filling loop.
- Vent all radiators from air starting with the lowest radiator and working your way up to the highest point.
- Check the pressure after venting. If the pressure has dropped under 1.0 bar then top up the system as described previously.
- Disconnect the filling loop and cap off.

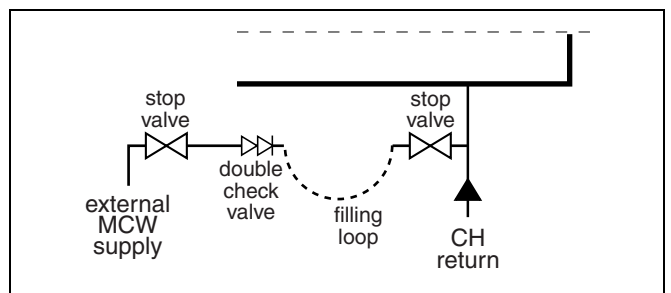

fig. 41 Connecting filling loop

To drain the boiler take the following steps:

- Close the CH return valve.
- Connect drainage hose (fig. 42).
- Close the CH return and CH flow valves.
- Connect draining hose to draining point on the manifold (fig. 42, item 1).
- Open draining point to drain the boiler (fig. 42, item 1).

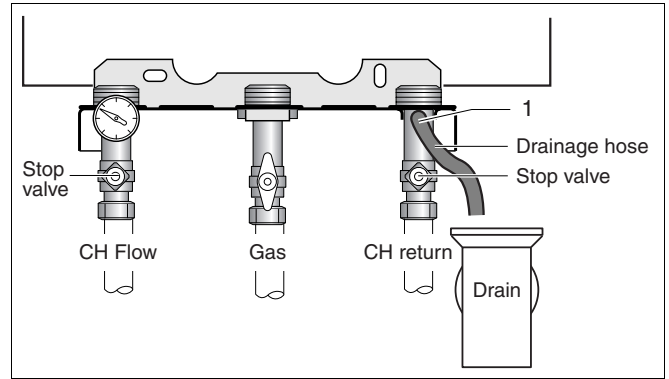

fig. 42 Draining the boiler

Fill the condensate trap

- Remove the condensate trap and fill with water (see fig. 43 and fig. 44).

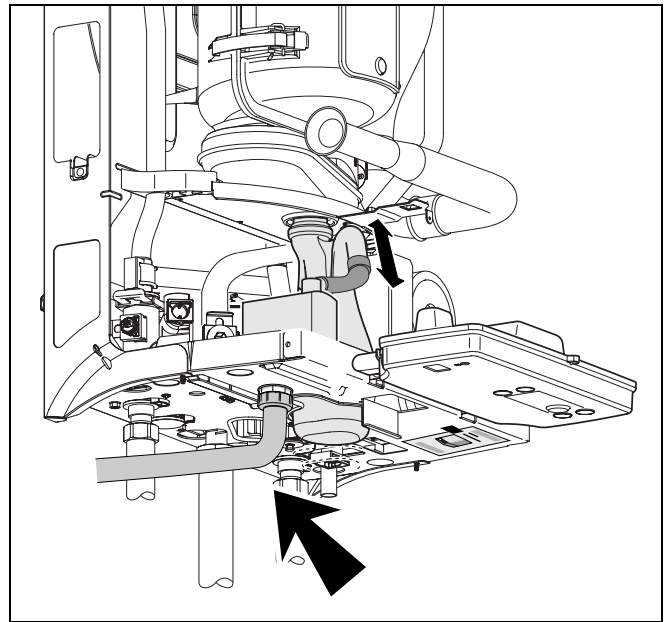

fig. 43 Disconnect hose from condensate trap

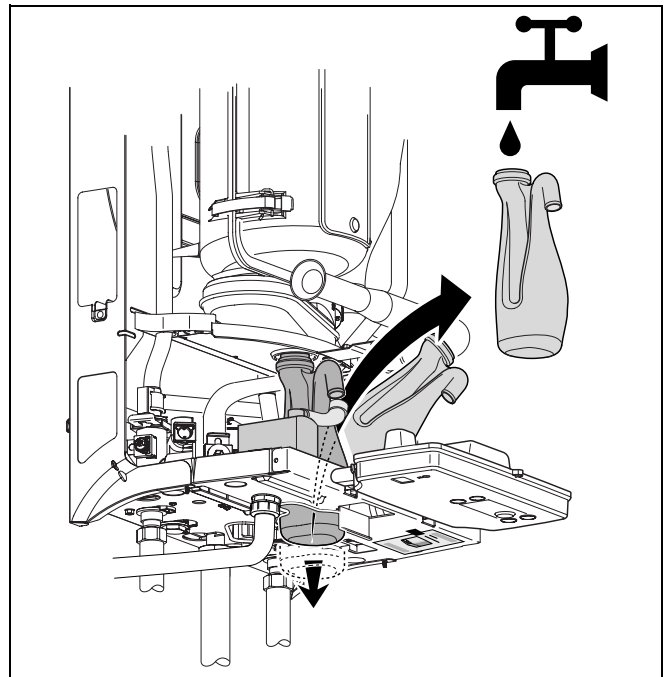

fig. 44 Remove the condensate trap and fill with water

2.1.2 DBA adjustments

The boiler is equipped with a DBA. This is the internal control of the boiler. The DBA is located behind the access panel.

The DBA allows you to operate the boiler and to make adjustments in its settings.

DBA overview:

1. Mains switch (see fig. 45)

Use this switch to turn the boiler on or off.

2. Reset button "⊖" (see fig. 45)

When a blinking code is in the display, it is possible to try and restart the boiler by pressing this button.



NOTE

It is not possible to reset the boiler when there is no fault code blinking in the display.

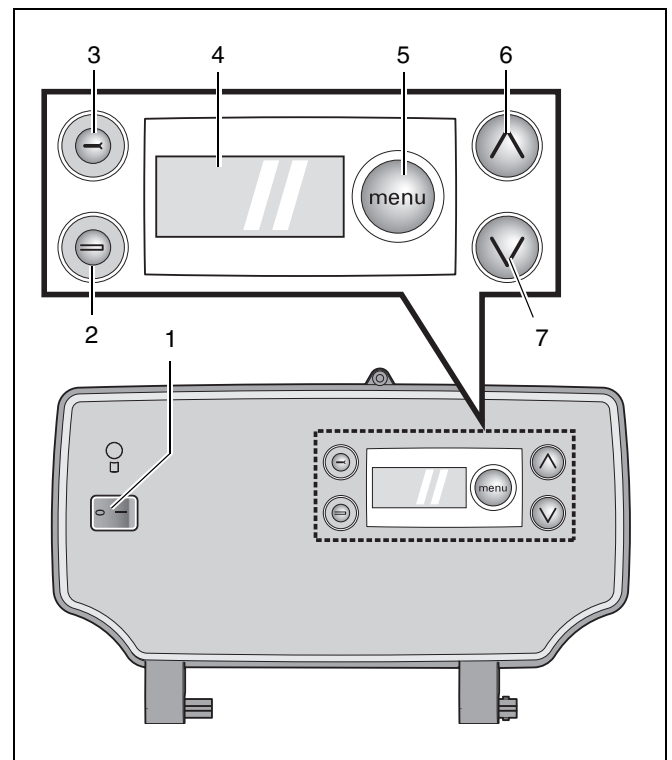

fig. 45 DBA

- item 1: mains switch
- item 2: "reset" button
- item 3: "service" button
- item 4: display
- item 5: "menu" button
- item 6: adjusting arrow up
- item 7: adjusting arrow down

3. Service Button "↶" (see fig. 45)

The boiler will operate on partial load when the Service button "↶" is pressed once. An open-end spanner "↶" appears in the top left hand corner of the display (fig. 46).

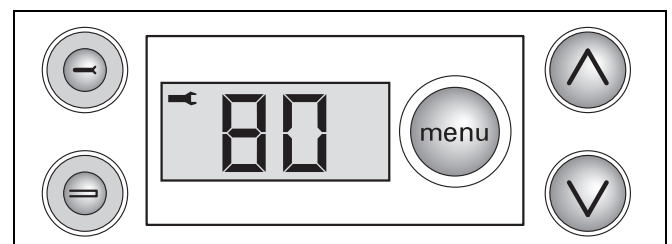

fig. 46 DBA with open-end spanner

Press the ▲ button if you want to make sure that the boiler is actually operating at partial load ('Lo' appears in the display, fig. 47).

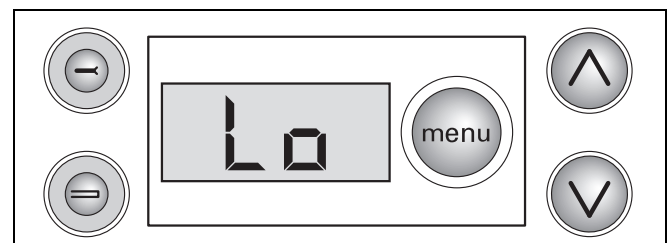

fig. 47 DBA display Lo

2 Commissioning

The boiler operates at full load when the Service button "⊖" is pressed again. An open-end spanner "🔧" appears in the top left hand corner of the display.

Press the "⬆" button if you want to make sure that the boiler is actually operating at full load ('Hi' appears in the display, fig. 48).

The boiler returns to regular operation when the Service button "⊖" is pressed once again or after the boiler has operated at partial- or full load for 30 minutes.

4. Display (see fig. 45)

The display visualizes settings, adjustments and fault codes (see fig. 49).

5. Menu button "menu" (see fig. 45)

The menu button "menu" allows you to scroll through the menu items.

Pressing the "menu" button once, the current DHW temperature (in combination with an external hot water cylinder) setting is displayed.

Pressing the "menu" button again gives the current setting of summer operation.

Pressing the "menu" button once more gives the current CH flow temperature setting.

6. and 7. Up "⬆" and Down "⬇" keys (see fig. 45)

These keys can be used for adjusting temperatures and activating or de-activating certain summer operation.

The "⬆" key when pressed gives the current operating status of the boiler.



Setting the domestic hot water (DHW) temperature (in combination with an external hot water cylinder)

- Press "menu" button once then adjust the DHW temperature to the desired temperature (40 °C - 60 °C) using the "⬆" and "⬇" keys (see fig. 50, item 1). Factory setting is 48 °C.

Setting the boiler to summer operation

When you want to make sure that your boiler will not operate for central heating in the summer then you can set the boiler to summer operation. The boiler will then only operate for DHW (in combination with an external hot water cylinder).

- Press the "menu" button (see fig. 50, item 2) twice. The current setting blinks.
- Use the "⬆" or "⬇" keys to adjust to desired setting.

	Central heating is on.
	Central heating is off (summer operation). DHW is still available (when external hot water cylinder is used).

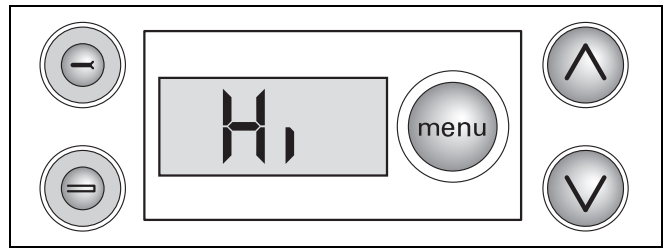

fig. 48 DBA display Hi

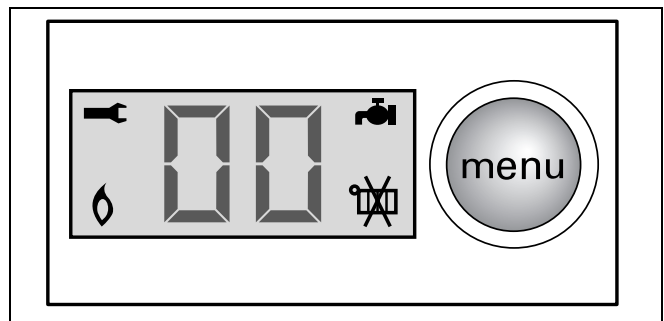

fig. 49 DBA display

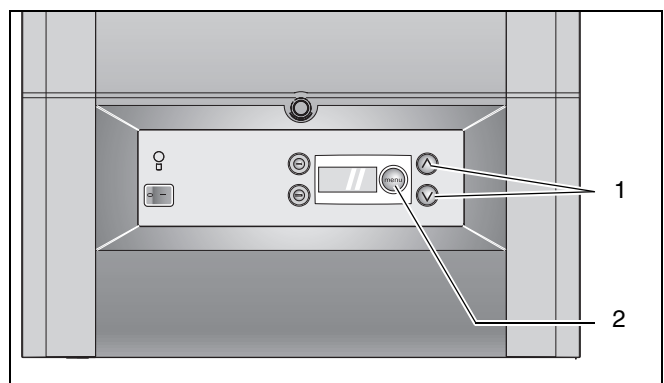





fig. 50 DBA - adjusting arrows



NOTE

When summer operation is active then the boiler will not operate for central heating until summer operation has been deactivated.

Setting the flow temperature

- Press  button (see fig. 50, item 2) three times then adjust the flow temperature to the desired temperature (30 °C – 80 °C) using the  and  keys (see fig. 45, item 1). Factory setting is 80 °C.

It is not possible to set the flow temperature when the boiler is set to summer operation.

Frost protection

The boiler has an automatic frost protection. When the CH flow temperature drops below 7 °C then the boiler will start up.

2.1.3 Checking for gas leaks

Use a suitable pressure gauge for the different pressure readings. It should be able to handle pressures up to 50 mbar with an accuracy of 0.01 mbar minimum.

- Disconnect the system from the power supply.
- Check all sections of gas pipework and connections for signs of leaks before starting up the system for the first time. If a leak is detected during tightness testing, use an approved leak detector to check all connections for possible escapes. The product must be certified as a gas leak-testing agent. DO NOT allow the product to come into contact with electrical wiring.

The test pressure of the gas pipe when the gas shut off valve is open may not exceed 150 mbar.



ATTENTION

Check the used measuring nipples for gas tightness.

2.1.4 Checking the gas type

It is very important that the gas type to which the boiler will be connected corresponds to the gas type the boiler is equipped with. If this is not the case, then the boiler must not be put into operation.

- Check the gas type with your gas supplier and compare this to the boiler's gas type as registered on the identification tag (see table 3).

It is possible to change the boiler to another gas type (see table 2). This accessory can be ordered from your supplier.

2.1.5 Measuring the gas-supply pressure (flow pressure)

There are two ways to measure the gas-supply pressure:

- measuring the standing gas-supply pressure (boiler not in operation);
- measuring the working gas-supply pressure (boiler operating at full power).

Type of gas	Factory settings of gas burners
Natural gas H	When delivered ready for operation and set to Wobbe index 14.1 kWh/m ³ (referred to 15 °C, 1013 mbar), applicable for Wobbe index range 11.3 to 15.2 kWh/m ³ . Inscription on gas-type indicating label: Category setting: 2H - G 20_20 mbar
LPG	After adaptation by a CORGI registered installer, the unit can be run on LPG. Inscription on gas-type indicating label: Category setting: 3P G 31_37 mbar

table 2 Gas-supply types

Type of gas	Gas injectors \varnothing [mm]		Venturi tubes
	Buderus 500		
Natural gas H (G20)	24/S		Standard
LPG	4.45		Standard
	3.45		Standard

table 3 Gas injector diameter

**NOTE**

The difference between the standing and working pressure may never be greater than 5 mbar. If the difference between the two is greater than 5 mbar then the pressure loss in the gas pipe is too great.

Measuring the standing gas-supply pressure

- Take the boiler out of service by pressing the mains switch (fig. 51, item 1) to "0".
- Close the gas shut off valve (fig. 52, item 1).
- Set the pressure gauge to "0".
- Attach a tube from the pressure gauge to the gas test nipple (the lower one, see fig. 53, item 2).
- Slowly open the gas shut off valve (fig. 52, item 2).
- Measure the standing gas-supply pressure.

Measuring the working pressure

- Take the boiler out of service by pressing the mains switch (fig. 51, item 1) to "0".
- Close the gas shut off valve (fig. 52, item 1).
- Set the pressure gauge to "0".
- Attach a tube from the pressure gauge to the gas test nipple (the lower one, see fig. 53, item 2).
- Slowly open the gas shut off valve (fig. 52, item 2).
- Open at least two radiators.
- Set the mains switch (fig. 51, item 1) to "1".
- Create a heat demand by pressing the service button "⊖" (fig. 51, item 2), until an open-end spanner "🔧" appears in the top left hand corner of the display.
- Measure the working gas-supply pressure.
- The working gas-supply pressure should be between: a minimum of 17 mbar and a maximum of 25 mbar (nominal connection pressure of 20 mbar) for Natural gas. a minimum of 30 mbar and a maximum 50 mbar (nominal connection pressure 37 mbar for LPG).
- Pull off the tube from the gas testing nipple.
- Tighten the screw of the gas testing nipple.

**ATTENTION**

If the required connection pressure is incorrect contact your gas supplier.

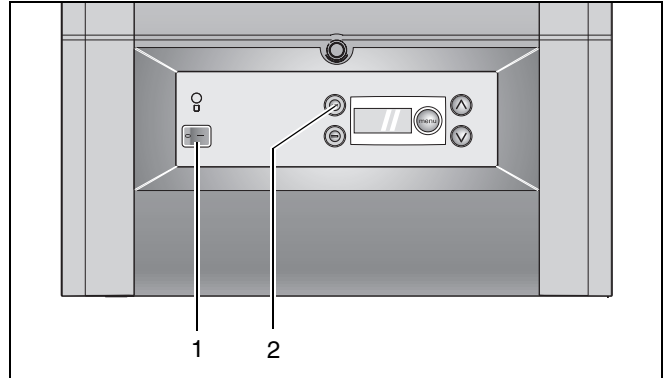

fig. 51 DBA front

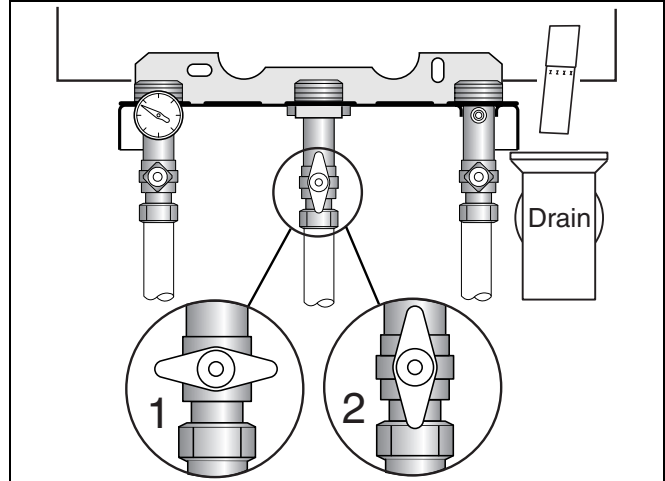

fig. 52 Gas valve

item 1: Gas valve closed

item 2: Gas valve open

Ensure that all disturbed joints and connections are checked for gas tightness on completion of tasks.

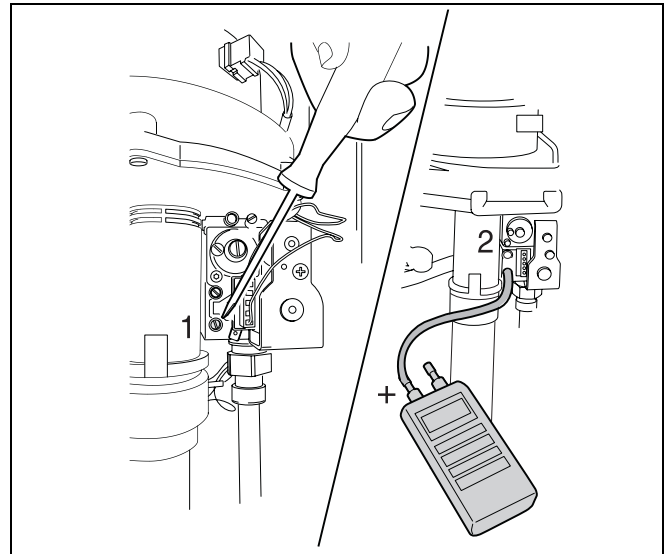

fig. 53 Measuring the gas-supply pressure

2.1.6 Checking the gas/air ratio and adjust as required

- Turn mains power switch to "0" (fig. 51, item 1).
 - Remove the casing of the boiler.
 - Shut the gas shut off valve underneath the boiler (see fig. 52, item 1).
 - Open at least two radiators.
 - Open the top measuring nipple (see fig. 54, item 1) with two turns.
 - Set the pressure gauge to "0".
 - Connect a tube from the "+" side of the pressure gauge to burner-pressure testing nipple (see fig. 54, item 2)
 - Open the gas shut off valve (see fig. 52, item 2).
 - Set the mains switch to "1" (fig. 51, item 1).
-
- Set the boiler to partial load by pressing the service button "⊖" once. A symbol of an open-end spanner "🔧" appears in the upper left hand corner of the display (see fig. 55).

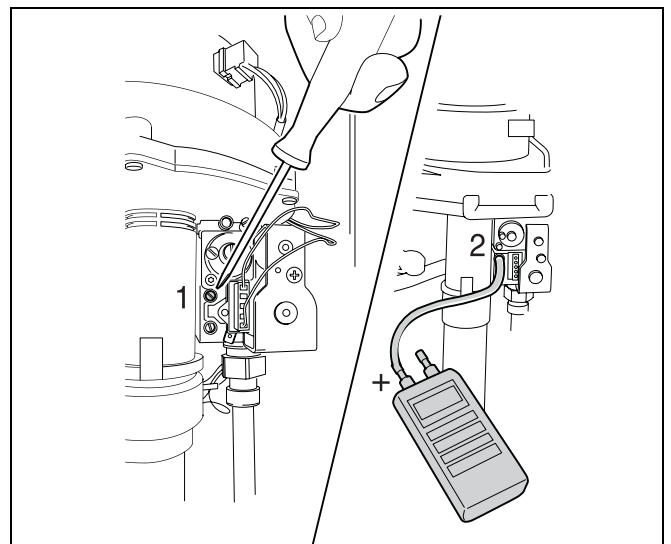

fig. 54 Check the gas/air ratio

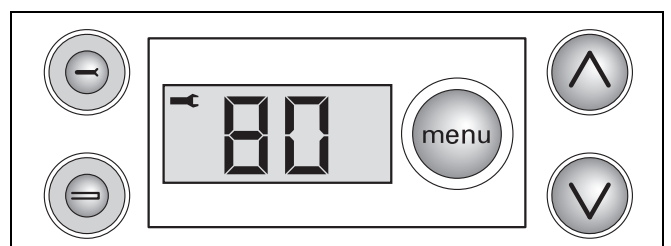

fig. 55 DBA with open-end spanner

- The optimum gas/air ratio is - 5 Pa (-0.05 mbar). The pressure difference should be between -10 and 0 Pa (see fig. 56).

If this is not the case then adjustment is needed:

- Remove the safety screw with a flat head screwdriver (fig. 57, item 1).
- Adjust the adjustment screw of the burner pressure to the correct gas/air ratio using a (4 mm) socket head wrench and by referring to fig. 56.

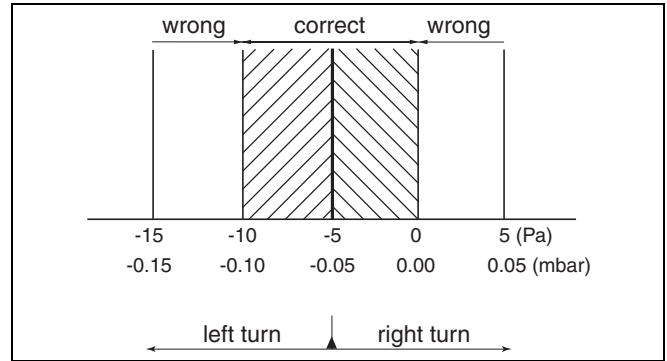

fig. 56 Pressure difference of gas/air ratio at partial load

- Replace the safety screw (fig. 57, item 1).
- Set mains power switch to "0" (see fig. 51, item 1).
- Shut the gas shut off valve (see fig. 52, item 1).
- Remove the tube from from the burner-pressure testing nipple (see fig. 54, item 1).
- Tighten the screw on the burner-pressure testing nipple.
- Open the gas shut off valve (see fig. 52, item 2).
- Turn the mains power switch to "1" (see fig. 51, item 1).



CAUTION

Check the test nipples for gas tightness.



NOTE

Technically it is not necessary to use a combustion analyzer for CO₂ measurements. The CO₂ level is secured by the gas/air ratio as described above.

A combustion analyzer, if available, can be used to confirm CO₂ levels (see technical specifications on page 7).

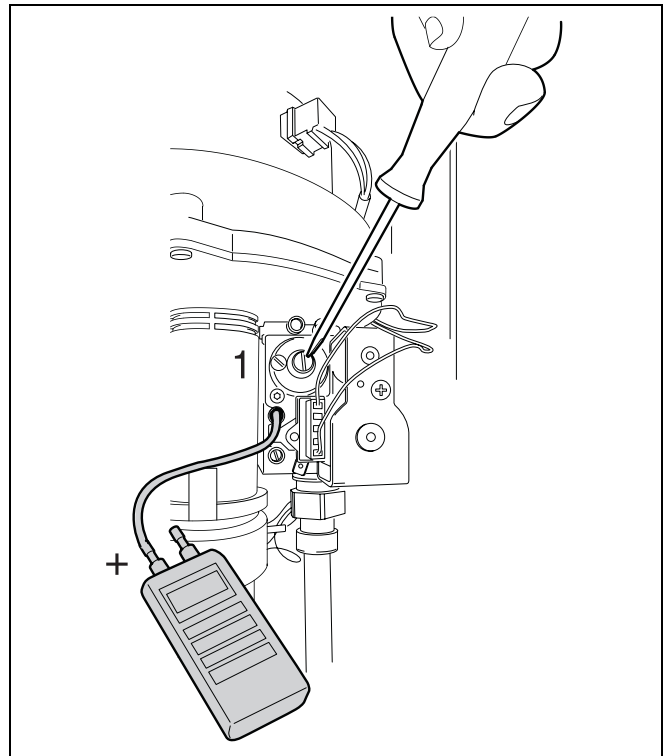

fig. 57 Adjust gas/air ratio

2.1.7 Gas rating test

- Isolate all other appliances.
- Press the service button "⊖" to set the boiler to full load.
- Ensure that there is no modulating of the fan gas valve.
- Carry out the Gas Rating procedure as described in "Essential Gas Safety" 3rd edition on pages 169-176.

2.1.8 Checking for leaks while boiler is in operation

- Use an approved leak detector to check all connections for possible leaks. The product must be certified as a gasleak-testing agent.
- Do not allow the product to come into contact with the electrical wiring.

2.1.9 Function testing



NOTE

During initial start-up and annual servicing, make sure that all control, regulating and safety devices are in full working order and, if applicable, check for correct adjustment.

Measuring the ionisation current (fig. 58)

- Turn the mains power switch to "0" (see fig. 51, item 1).
- Remove the casing.
- Loosen the connector-and-socket connection of the ionisation electrode and connect the multimeter in series.
- On the measuring device, select the μ -direct current range. The measuring device must have a resolution of at least $1 \mu\text{A}$ (1 micro ampere).
- Set mains power switch to "1" (see fig. 51, item 1).
- Set the boiler in to partial load by pressing the service button "⊖" once.
- Measure the ionisation current. The ionisation current being checked must measure $>2 \mu\text{A}$ (>2 micro ampere) direct current.
- Enter the reading on the report form.
- Set the mains power switch to "0" (see fig. 51, item 1).
- Remove multimeter and restore the connector-and-socket connection to its original state.
- Refit the casing and secure the boiler with the radiator key (see fig. 59).
- Set the mains power switch to "1" (see fig. 51, item 1).

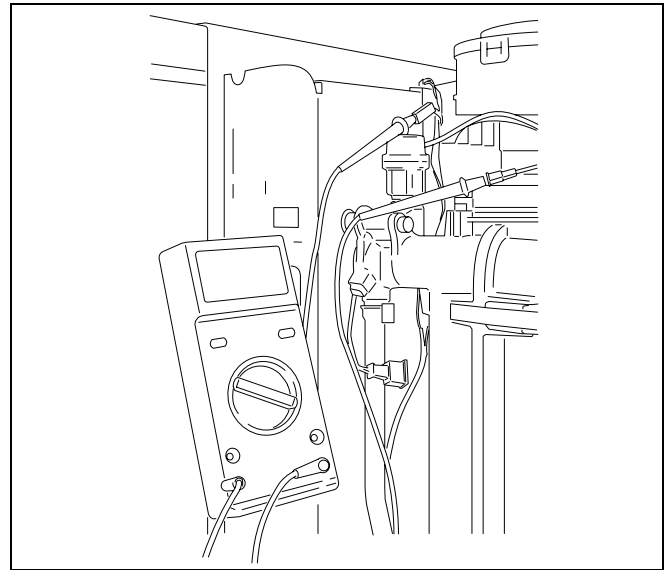

fig. 58 Measuring the ionisation current

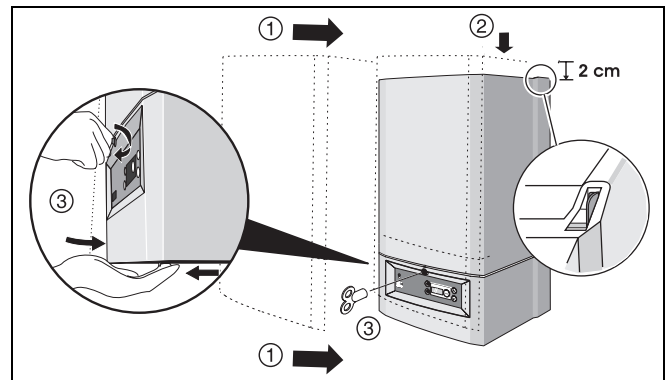

fig. 59 Refit casing

2.1.10 Handing over

After completing the installation and commissioning of the system the installer should hand over to the householder by the following actions:

- Hand over all relevant documentation to the end user and explain his/her responsibilities under the relevant national and regional regulations.
- Explain and demonstrate the lighting and shutting down procedures.



NOTE

Always keep the user manual and installation and servicing instructions available for feedback.

3 Inspection

3.1 General directions

- Do a visual and functional test of the installation.

3.2 Preparing the boiler for inspection

- Disconnect the boiler from the mains power supply.



DANGER OF FATAL INJURY

due to electric shock when system is opened.

- Before opening the system: disconnect the heating unit at the emergency OFF switch or the corresponding circuit breaker of the house power supply.
 - Ensure that the heating system cannot be reconnected by accident.
- Remove the burner housing or cover from the heating boiler.



NOTE

If the gas supply pipes are to be disconnected from the burner, the housing **MUST ONLY** be removed by a qualified service technician and checked for tightness on reassembly.

3.2.1 Internal leak test

- Disconnect the boiler from the mains power supply.

Do not allow the product to come into contact with the electrical wiring.

3.2.2 Check the combustion chamber and heat exchanger for pollution

3.2.3 Check the burner

3.2.4 Check the functioning and safety of the flue gas exhaust

3.2.5 Check the pre-pressure of the expansion vessel

3.2.6 Check the hot water cylinder for leakage

3.2.7 Check the programming of the room thermostat

4 Maintenance



NOTE

The described cleaning of the burner and heat exchanger is only necessary when the boiler is heavily soiled. Otherwise it is sufficient to clean the burner and heat exchanger with a soft brush or compressed air without disassembling them.

4.1 Cleaning the heat exchanger and burner

- Switch the boiler off by setting the mains switch to "0" (see fig. 51, item 1).
- Close the gas shut off valve (see fig. 52, item 1).
- Unlock the securing screw with a radiator key and remove the casing.
- Loosen the gas connection between the gas supply and the gas air unit (fig. 60).

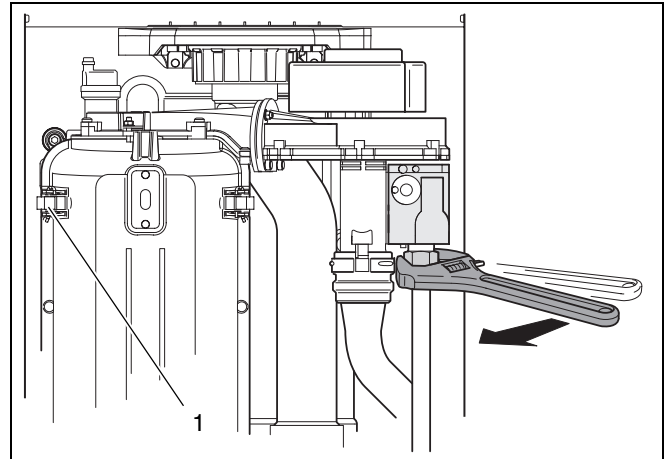

fig. 60 Loosen gas connection

- Remove the connectors (fig. 61, item 1, 2 and 3) from the gas air unit.
- Remove the air silencer from the gas air unit (fig. 61, item 4).
- Then remove the connectors of the ionisation electrode (fig. 61, item 6) and the glow ignitor (fig. 61, item 5).

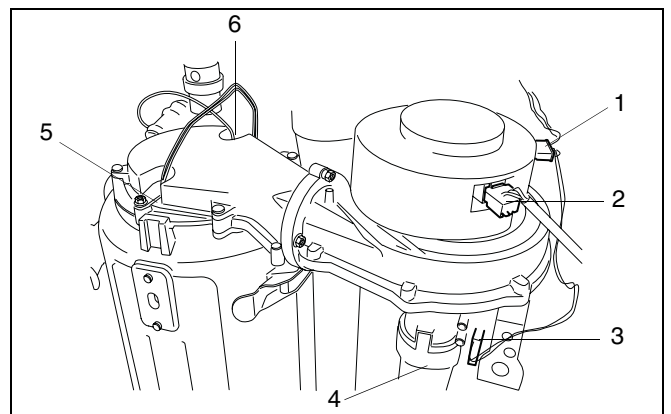

fig. 61 Remove connectors of the gas air unit

- By turning the unit a quarter turn (fig. 62, step 1), the unit can be removed by lifting it out of the boiler (fig. 62, step 2).
- Clean the burner when necessary. The burner may only be cleaned with a soft brush or compressed air.



CAUTION

Replace the burner seal after removing the burner from the gas air unit.

- Now the front cover of the heat exchanger can be removed by opening the latches (fig. 60, item 1).

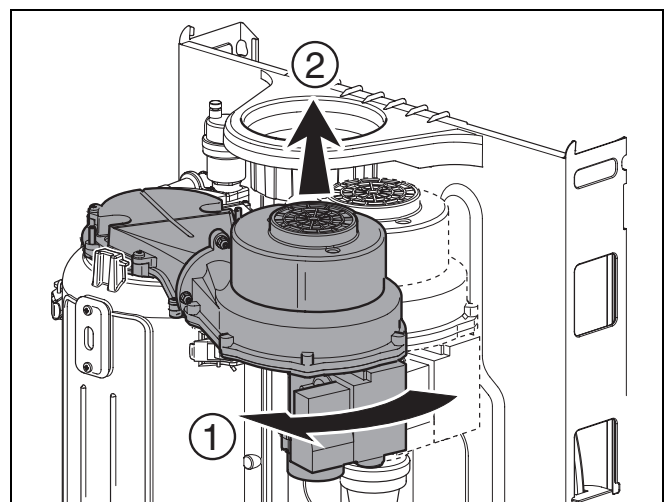

fig. 62 Remove gas air unit

- Remove the restrictor baffle from the heat exchanger (fig. 63, item 1).
- Inspect the heat exchanger. When needed clean the heat exchanger with a soft brush or compressed air.

**NOTE**

Only when a heat exchanger is heavily soiled is it recommended to drain the system, to remove the heat exchanger for cleaning.

- Check the seal for damage. Always replace the seal when in doubt.
- Reassemble in reverse order.

4.2 Cleaning the condensate trap and syphon

- Remove the condensate trap (fig. 64 and fig. 65).

- Clean the condensate trap with tapwater and a brush.
- Fill the condensate trap with water and reassemble.
- Undo the condensate drain connection (see fig. 64, item 1) and remove the syphon.
- Rinse and refit the syphon.

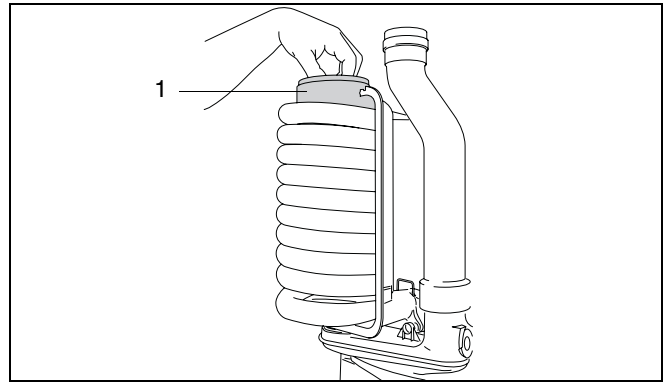

fig. 63 Remove restrictor baffle

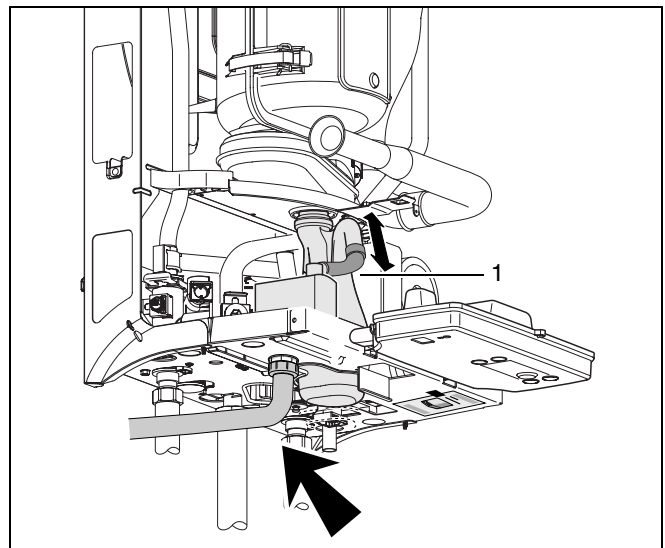

fig. 64 Disconnect hose from condensate trap

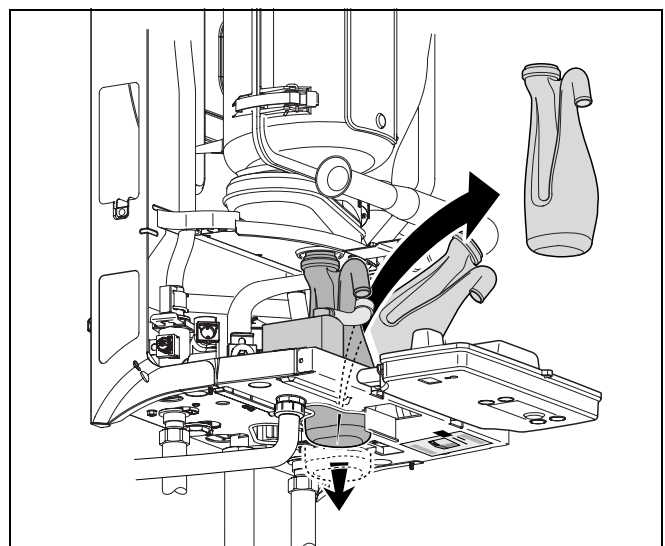



fig. 65 Remove the condensate trap

5 Appendix

5.1 Fault codes

Code	Key to display code	Key to display code
□	Ч	The flow sensor or safety sensor has detected that the current CH flow temperature is higher than 95°C.
1	⌈	The flue-gas STL (fume-monitoring device) has detected a temperature higher than 105°C. The flue-gas STL is opened.
2	F	The flow sensor and safety sensor have, after burner startup, not detected any temperature increase in the heating water, or they have determined that the temperature difference between The flow sensor and safety sensor is too high.
	P	The flow sensor has detected a temperature increase, in the heating system water, of over 5 °C/sec.
3	R	The tachometer signal from the fan has failed during the operating phase.
	L	The tachometer signal from the fan is not present during the preoperative or operating phase or there is no current of air after a certain time.
	Ч	The fan runs too slowly or too fast.
4	R	The flow sensor and safety sensor have detected a CH flow temperature of over 105 °C.
	E	The sensor test has failed.
	L	The contacts of the flow sensor and safety sensor are shorted to each other, or there is a short-circuit to earth (ground), or the flow or safety sensor has detected a CH flow temperature of above 130 °C.
	P	The contacts of the flow sensor or safety sensor are broken.

Code	Key to display code	Key to display code
6	R	After four startup attempts, the system has detected an insufficient ionisation current.
	⌈	The system has detected an ionisation current before burner startup or an ionisation current has been measured as soon as the burner shuts down.
	L	The flame goes out during the operating phase.
7	⌈	The power supply was shut off during a crucial breakdown.
9	R	The DBA control panel is defective.
	F	The contacts of the gas valve have been broken.
	H	The DBA control panel is defective.
	L	The contacts of the gas valve have been broken or the DBA control panel is defective.
	P	The DBA control panel is defective.
	Ч	Short circuit in the gas valve.
E	1	The DBA control panel is defective.
	2	
	3	
	4	
	R	
	⌈	
	F	The contacts of the KIM (EEPROM on the DBA control panel circuit board) may be loose or short-circuited.
r	E	Reset is carried out. This code appears after the reset button  is pressed for 5 seconds.

5.2 Residual pump lift

This graphic shows the amount of pump lift remaining for the heating system.

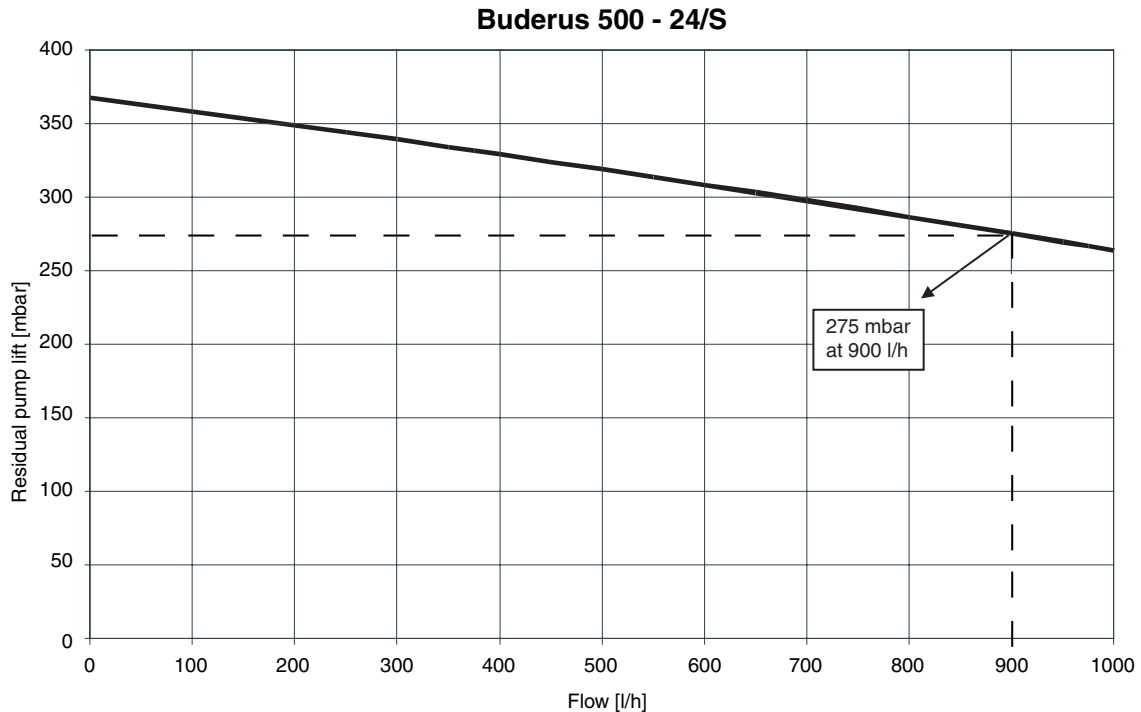

5.3 Spare parts list

The following are parts commonly required due to damage or expendability. Their failure or absence is likely to affect safety or performance of this appliance. For a pictorial representation of the part see the respective position number on the exploded view pictures on page 46.

	Description	Product No.
1	Casing	78155
2	Bracket	38092
3	Grommet cover	78145
4	Fan	73639
5	Fan seal (set of 5 pc.)	73640s
6	Gas injector 2E	73210
7	Gas valve	73645
8	Venturi	73641
9	50mm seal	73574
10	Air silencer tube	73646
11	Gas/air supply valve	73756s
12	Syphon	78173
13	Gas/air supply	73663
14	Burner seal (set of 2 pc.)	73669s
15	Burner	73668
16	Heat exchanger - Gas/air supply seal	73728

	Description	Product No.
17	Backside heat exchanger	73657
18	Gasket heat exchanger	73578
19	Heat exchanger	73659
20	Frontside heat exchanger	78125
21	Sight glass	73662
22	Combustion divider	73670
23	Glow ignitor	78105
24	Ionisation electrode	38320
25	Ionisation electrode seal (set of 2 pc.)	73666s
26	Glow ignitor seal (set of 2 pc.)	73665s
27	Bracket ionisation electrode and glow ignitor (2 pc.)	73667s
28	Shield glow ignitor	38453
29	Concentric adapter	78120
30	100mm Lipring	78121
31	60mm seal (bottom flue gas pipe)	73563

	Description	Product No.
32	Flue gas pipe	78122
33	60mm seal (top flue gas pipe)	73736
34	Flue gas pipe seal	73579
35	Flue gas thermostat (STL)	73376
36	Condensate collector	73630
37	Condensate trap	78123
38	Connection return	73583
39	Gas pipe	78126
40	Connection supply	73672
41	Automatic airvent	38618
42	Spring heat exchanger	73582s
43	O-ring heat exchanger (set of 10 pc.)	73580s
44	Heat exchanger seal (set of 2 pc.)	73584s
45	Safety sensor	78154
46	Supply pipe	78130
47	Pump Uper 15-50	78142
48	Connection return pipe	78133
49	Return pipe	78132
50	Connection return system	78168
51	–	
52	–	
53	Securing pin of the servomotor	73687
54	Discharge pipe of pressure relief valve	78134
55a	Pressure relief valve 3 bar	78198
55b	Key to Pressure relief valve 3 bar	78202
56	By-pass	78143
57	Expansion vessel pipe	78135
58	Expansion vessel	78163
59	–	
60	–	
61	–	
62	Connection supply system	78169
63	Flow sensor	78136
64	–	
65	–	
66	–	
67	Clips (set of 2x3 pc.)	78156s
69	CH connector	78161
70	–	
71	DBA 24/S and 28/C	78127
72	Power switch	73660
73	Cable harness	78129
74	Clips (set of 5 pc.)	73653s

	Description	Product No.
75	Clips (set of 5 pc.)	73056s
76	Condensate trap seal	73463
77	Drainpipe seal (set of 5 pc.)	73638s
78	O-ring (set of 10 pc.)	78151s
79	O-ring small (set of 10 pc.)	78152s
80	O-ring 73 x 5	78177
81	O-ring 48.9 x 2.62	78178
82	O-ring (set of 10 pc.)	78157s
83	–	
84	–	
85	RTH Converter	78079
86	O-ring (set of 10 pc.)	38472s
87	¾" Seal (set of 10 pc.)	15002s
88	O-ring (set of 10 pc.)	38478s
89	Cover seal	78174
90	Seal	73561
91	O-ring (set of 2x2 pc.)	73642s
92	Seal (set of 10 pc.)	73738s
93	1" Seal (set of 5 pc.)	73527s
94	Casing lock	73901
95	Cut off cock with pressure gauge	78150
96	–	
97	Gas valve	78201
98	–	
99	Valve CH return	75964
100	Spring (set of 5 pc.)	73490s
101	Spring Hydroframe (set of 5 pc.)	78164s
102	–	
103	1" Seal (set of 5 pc.)	73527s
104	–	
106	–	
–	Spring gaspipe (set of 5 pc.)	73531
–	LPG kit 24 kW-28kW	73734
–	O-ring sensor (set of 10 pc.)	38434s
–	O-ring 16x2 pressure relief valve (set of 10 pc.)	73729s
–	Fuse 2.5 AT (DBA) (set of 10 pc.)	73739s
–	O-ring (large) flow sensor (set of 10 pc.)	78153s
–	O-ring 9.19 x 2.62 sensor supply/return (set of 10 pc.)	78175s
–	Screw 4 x 20 Hydroframe (set of 5 pc.)	78179s
–	Screw M5 x 30 Pump (set of 5 pc.)	78180s
107	Receiver bracket	78200
108	Wall spacing frame	75972

Exploded view Single unit (Buderus 500-24/S)

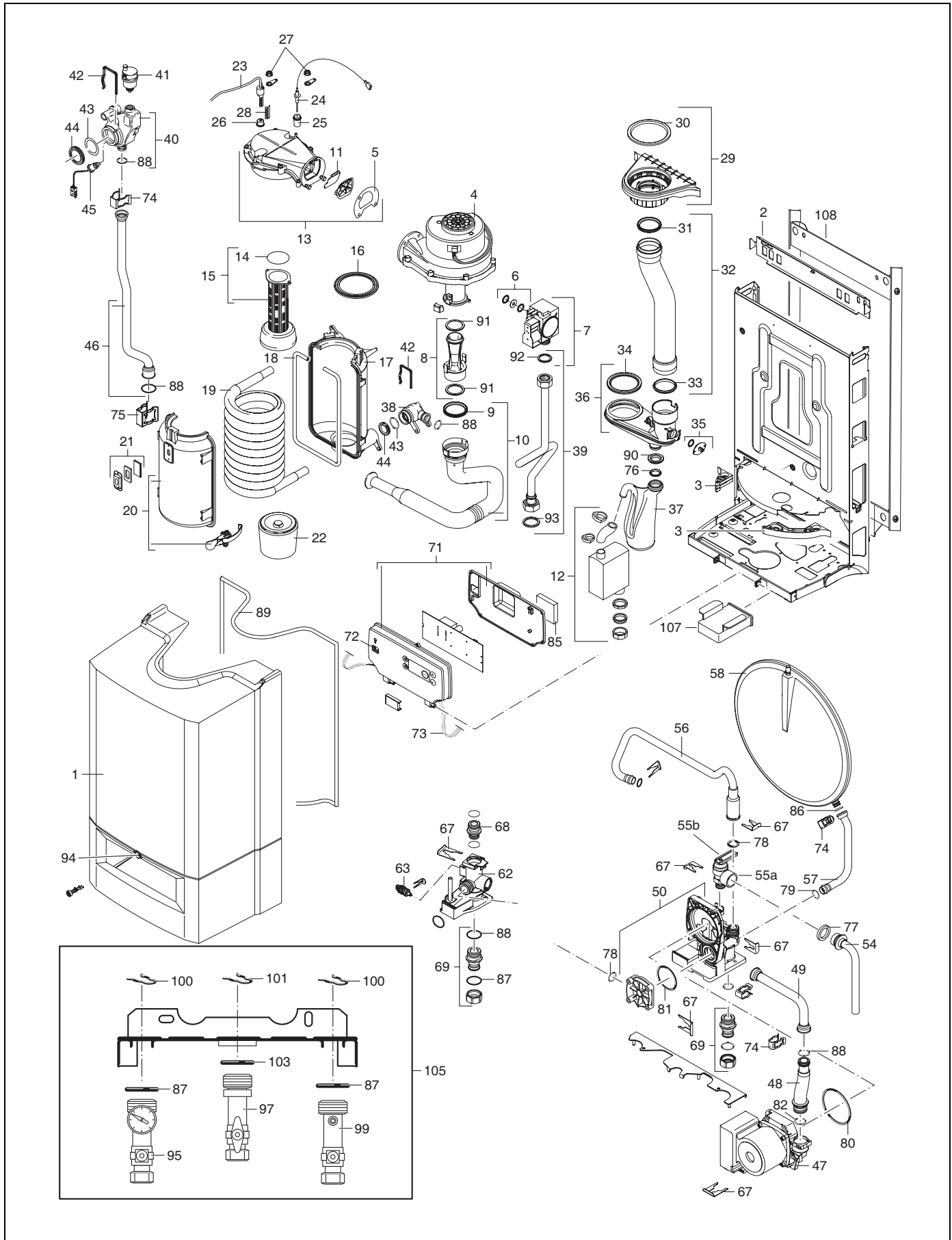

6 Index

A

Automatic air vent 31

B

Bracket for ModuLink 250 RF 10

E

Electrical connections

 Mains connection 21

H

Horizontal flue 16

I

Inspection 40

M

Maintenance 41

manifold assembly 11

P

Pipe connections

 Hot-water connection 12

Place of installation 10

T

Technical specifications 7

Type of gas supply 7, 35

V

Vertical flue 17

W

Wobbe index 35

Buderus

Heating system specialist:

Buderus
Cotswold Way
Warndon
Worcester
WR4 9SW
Telephone: 01905 - 752 936
Fax: 01905 - 753 130

Customer Services:	Tel: 0870 - 421 5933	
Technical Product Support:	Tel: 0870 - 421 5944	
Sales:	Tel: 01905 - 752 640	Fax: 01905 - 456 445 / 455 394
Returns:	Tel: 01905 - 752 531	Fax: 01905 - 455 392
Spares:	Tel: 01905 - 752 576	Fax: 01905 - 754 620

www.buderus-domestic.co.uk

Buderus is a trading name of BBT Thermotechnology UK Ltd.